

Department of Electrical and Computer Engineering

Test Specifications for

FM Converter

Submitted to:

Professor Joseph Picone
ECE 4522: Senior Design 2
Department of Electrical and Computer Engineering
Mississippi State University
Mississippi State, Mississippi 39762

December 3, 2001



Submitted by:

B. Blackwell, D. Harkins, G. Henry, Daniel Lack, and S. Welch
Faculty Advisor: Dr. Georgios Lazarou
Department of Electrical and Computer Engineering
Mississippi State University
Box 9571
Mississippi State, Mississippi 39762
Phone: (662) 325-3649 Fax: (662) 325-2298

Email: dmh4@ra.msstate.edu, brb2@ece.msstate.edu, gph1@ece.msstate.edu, and
saw1@ece.msstate.edu

EXECUTIVE SUMMARY

Standard car radios do not have a means to input external audio devices. This presents a problem for many users who would like to play portable devices through their automotive speaker system. What is needed is an inexpensive method that will allow someone to play any type of audio device through the speakers. The option currently available to the consumer, other than purchasing a costly new audio device such as a CD or mp3 player, is to use a tape adapter.

Tape adapters achieve the goal of playing portable devices through an existing system's speakers, however, there are drawbacks associated with these units. One problem is that the adapter requires an automobile to have an existing tape player. Another shortcoming is the audible tape "hiss" caused by the heads used by the tape player. This problem is amplified when the tape adapter is operated in or exposed to the extreme heat or cold an automobile interior endures. These extreme conditions shorten the useful life of the adapter. In addition to the sound quality issues related to these adapters, the wiring required to operate them can become an inconvenience.

We propose that a more convenient and widely applicable means of linking two systems can be accomplished by using an FM receiver as the interface rather than the tape player. Our adapter will input a signal from any standard headphone jack and convert it into a radio broadcast that can be received by any FM radio. Converting a signal in this way is much more versatile than with existing technology because most automobiles have an AM/FM radio but many lack a tape player.

Our team chose to develop a wireless interface with the radio rather than using a coaxial cable. Using a coax produces a clear signal with low radiation and interference but is inconvenient to install. Having a wireless interface allows the user more portability and convenience while still maintaining high signal quality. Because of the desired high signal quality, FM radio was chosen over AM [6]. FM radio is less susceptible to interference from weather and nearby electrical systems. Using FM also allows clear transmission of a stereo signal. Transmission with stereo was chosen over mono because of its increased sound quality and wide appeal.

Because of the large number of FM radio stations, it will be necessary for the consumer to tune our device to an unoccupied frequency. This will be done using a tuner with a liquid-crystal display (LCD) that will allow the user to quickly select a frequency that corresponds to the unused space selected on the radio. Typical decibel signal to noise ratio specifications for an FM receiver is 50-60 db while a CD player usually operates at 90-105 db [7]. Our device's desired operating range is 70-82 db.

Since our converter will be used in a variety of environments, ease of transportation and durability are key issues [8]. The converter will be able to run on four AA batteries as well as offer the option of using 12V DC or 120V AC adapters that can be purchased separately. Having additional power options will enable the customer to use the converter in his or her car or at home without shortening battery life.

TABLE OF CONTENTS

ABSTRACT.....	4
1. INTRODUCTION.....	4
2. PROBLEM.....	5
3. OBJECTIVES.....	3
4. APPROACH.....	9
4.1 Theory of Operation.....	10
4.2 Selection of Parts.....	13
4.3 Frequency Selection.....	25
5. TEST SPECIFICATION.....	27
6. TEST CERTIFICATION.....	28
7. SUMMARY.....	26
8. FUTURE WORK.....	32
9. GOALS VS. RESULTS	37
10. INPUT VS. OUTPUT	39
11. ACKNOWLEDGEMENTS.....	39
12. REFERENCES.....	39

1. INTRODUCTION

The music industry, along with the consumer electronics industry, has seen incredible developments in recent years. Reproducible music has gone from scratchy phonographs to reel-to-reel recordings to compact disks and mp3 files in a relatively short period of time. These developments have been driven by several common objectives. Despite the wide variety of accomplishments, they have either improved sound quality, increased portability of music, or improved functionality and ease of use. These objectives have been accomplished with the all-important constraint of cost being factored into consideration. These developments have been welcomed and widely accepted. There has also been one nagging problem with all of the technological improvement. What about the consumer who has a large investment in outdated equipment? Progress does not come without a price. Many frustrated consumers have been forced to put their costly, outdated equipment in a closet (or the nearest trash can) because it was not compatible with newer devices. Essentially, an eight-track tape cannot be played in a CD player.

Many inventions in this arena have been sent to market but all have had flaws. The most common is the tape adapter. The tape adapter does allow the user a means of listening to an external device through a tape player (provided they have an in-dash tape player), which many newer cars do not have. Tape adapters have wires that get in the way, and they also make a hissing noise. Both of which keep them from fully accomplishing their goal. Many consumers have grown cynical about the next generation of technology because they dread the ensuing expense needed to stay current with the latest developments.

There is a medium that has existed and stayed prevalent throughout many technological breakthroughs. FM radio was standardized in the 1930s with stereophonic transmission for the commercial FM broadcast band starting in 1961 [1]. Since then, it has been a popular and widely used form of communication. Despite its long-term popularity and widespread use, converting audio signals from external devices to FM receivers has not been effectively implemented for the commercial market. Being able to use radio as the conversion medium is highly desirable. Not only does the user eliminate bothersome wiring needed by other methods, all he or she needs to do to be able to listen to the converted signal is have access to an FM radio. The recent trend in automotive technology is for a car to come without a tape player and only a CD player. Many cars that do have a CD player do not have a tape player. It is possible to listen to an external CD player if you have an existing tape player but not vice versa. No matter what extras are added, most any modern automobile comes with an AM/FM radio as standard equipment.

This widespread availability opens markets for an FM converter that other means of conversion simply could not access. More people will be able to convert more devices in more ways than ever before. There are limitations to such a device. The sound quality that would be available for transmission will not be CD quality since standard radio

transmission techniques would be used. We feel that many consumers would gladly trade a slight drop in quality for the tremendous jump in availability and portability.

The design constraints for the converter are as follows:

1. **Operating Frequency:** The unit will have the ability to operate throughout the standard FM spectrum of 87.9-107.9 MHz.
2. **Weight:** The unit's target weight is eight ounces.
3. **FCC Requirements:** Our device must be compliant with FCC rules and regulations [3].
4. **Signal Clarity:** The unit will be able to broadcast a stereo signal using FM transmission. [1].
5. **Size:** The unit will be approximately 5" x 3" x 3".
6. **User Interface:** The unit will feature a push-button style tuner. An LCD will be used to display the operating frequency. Also, an indicator light will be used so the user can verify that an input signal is present.
7. **Power Requirements:** The unit will operate on four AA batteries or optional power input.
8. **Cost:** The target cost for the retail consumer will be approximately thirty-five dollars.
9. **Audio Input:** The converter will use eight inch mini-lugs.

These design constraints should allow us to produce a design that is both functional and practical. However, the final and most telling test we can subject our product to is the field test. Observing how this device will perform in a real world environment will be crucial in deciding how viable this product is.

2. PROBLEM

In the ever-changing world of audio technology, keeping track of new equipment can become a daunting task. Those who desire to stay on the cutting edge of new technology will find themselves going to great expense. This leaves the audio enthusiast with two options: either upgrade to costly new equipment, or find a means of making new technology work with older equipment. The second option is appealing to consumers, if it can be accomplished economically without sacrificing quality.

For years, many companies have tried to overcome these difficulties by producing different types of adapters and converters. Several different types of interfaces have been

used. Until now, all of the devices that have been used for this purpose have either had limited applications or poor quality. Interfaces such as tape adapters have been common for years. While they allow the user to play one device through another, they have shortcomings as well. They offer limited signal quality and the wiring required for them can be bothersome.

A device is needed that would be compatible with different types of audio interfaces. The new adapter would allow the consumer to operate an existing tape player, CD player, or any other specialized device with equipment he or she already owns. Ideally, the device would not require the consumer to make a physical connection to the existing equipment. Most importantly, the music quality must remain high when the adapter is used. FM radio is the most commonly used medium in modern automobiles as well as other environments. Because it is so widely used, it is a very desirable means of conversion. More consumers have access to it and are more familiar with the technology involved.

In addition, the device must be portable. Having an adapter that will perform the needed functions is not very useful if it cannot be used in multiple environments. The device must have the freedom to be personally transported in multiple environments. In order to accomplish this, the device must be small and lightweight while having the option to work off battery power and standard power outlets. Adapters can be purchased separately by the customer, which will allow him or her to power the converter using a 120V AC source or a 12V DC source. This enables the user to operate the converter in his or her car or at home without decreasing battery life.

Our project is a portable FM converter that will bridge the technology gap. Our device will receive any signal from a standard, headphone jack adapter and broadcast it as an FM signal that can be received by any standard FM radio. The consumer could then adjust the device's frequency to an appropriate station. This would increase convenience and reduce interference caused by area radio broadcasting at the same frequency. High signal clarity combined with the convenience of this device will make it desirable to many consumers who would like to use new audio technology but don't have the time or money to change their equipment.

There will be many technical challenges to get such a device to operate properly. Everything from antenna loading to harmful interference with other devices will be an issue. The biggest challenge will be to transmit a signal that will be clear enough to be acceptable to the intended user without causing unwanted interference on other equipment. Part 15 of the FCC regulations on FM radio broadcasts governs these requirements. Designing an appropriate antenna and how to mount it will present problems as well.

Our converter will allow the user to tune to a desired transmitting frequency. The user will use a push-button style tuner to change frequencies. An LCD will be used to display the operating frequency. The user will pick an unused frequency on his or her radio dial;

then, tune the converter to that frequency. Being able to tune to different frequencies will allow the consumer to have clear transmission anywhere.

3. OBJECTIVES

The biggest concern with this type of device is the quality of the signal that it will produce. A consumer will not be happy with his or her new purchase if the music they are playing on it does not meet their expectations. This is a major obstacle to overcome. There are many sources of interference that will deteriorate the input signal. Everything from “engine noise” to weather can affect output clarity. Several possibilities to reduce these effects will be explored during the design and testing phases of this project. External antennas, transmitter proximity and many other design changes will be considered to keep undesirable effects to a minimum.

3.1 Operating Frequency:

FM radio stations operate within the frequency range of 87.9 MHz to 107.9 MHz. With radio stations operating at different frequencies from location to location, we need a device that will change to an unused frequency in its respective area. Our device will allow the user to tune to a clear frequency.

3.2 Weight:

Our target weight for the unit is eight ounces (without batteries). This weight is approximately equal to many portable audio devices. Keeping the weight to a minimum is preferred to keep the device portable.

3.3 FCC Requirements:

Part 15.2 of FCC regulations allow any personal transmitter a broadcast strength of no more than 250 $\mu\text{V}/\text{m}$ at a radial distance 3 meters from the transmitter. The transmitter will need to be located as close as possible to the receiver’s antenna due to signal strength decreasing as distance from the antenna increases [3].

3.4 Signal Clarity:

At best, we can expect a radio to receive our signal slightly better than it would a clear FM signal from a standard broadcast station. Our device's ability to transmit a clear signal will depend on the quality of the radio's receiver as well as other environmental factors. This will cause the unit's performance to vary among radios. Distance between the transmitter and receiver will also greatly affect the device’s performance [1]. Typical decibel signal to noise ratio specifications for an FM receiver is 50-60 db while a CD player usually operates at 90-105 db. We expect our device to operate in a range of 70-82 db.

3.5 Size:

One of the device's most alluring qualities will be its ability to travel wherever the user goes. This means that it has to be small enough to be easily moved and used in different environments. Our target size is 5"x 3" x 3". 3" of clearance will be needed to use the four AA batteries that will be used to power the device. Another constraint on size is the LCD. A 5"x 3" area is needed to mount the LCD properly. The 3" depth will be needed for component clearance inside the case and to help eliminate interference.

3.6 User Interface:

The user interface for the converter will allow the user to adjust the frequency using a push-button style tuner with an LCD to display the operating frequency. The user can find an unused station on his or her receiver and then tune the converter to the same frequency. An LED will be used to inform the user that an active signal is present on the input to the device.

3.7 Power Requirements:

The device will operate using four AA batteries. Other power options will be available to the user. Six-volt DC adapters can be purchased separately and used to power the converter using a 120V AC source. Six-volt adapters for cigarette lighter sources can also be purchased. Because of the ability to use the device with batteries, the power consumption of the device must be kept to a minimum to maximize battery life. AA batteries were chosen because of their long battery life (approximately 2850 mAh rated capacity for 25 mA constant drain).

3.8 Cost:

The estimated consumer retail cost of the converter is thirty dollars. This projected cost is calculated by estimating the total cost of the components that are to be used in fabrication of the device. The headphone jack connector, LCD, and wiring will be a significant factor. These components will be more expensive than the electronic components but are still low-cost items. Those factors help determine the cost of the device. To arrive at the retail price, this information was used along with a consumer survey asking various prospective customers what they would be willing to pay for such a device along with other questions.

3.5 Audio Input:

The converter will have an input for eighth inch input. A cord will be supplied with the unit that will have double-sided, male, eighth inch connectors, commonly known as mini-plugs.

4. APPROACH

The overall system structure shown in Figure 4-1 is a basic block diagram of our approach to our design. Our device operates when an external audio device is connected into the converter via a mini-plug connection cord. The device then converts the signal into an FCC compliant signal. The modulated output signal is transmitted through the air where any FM receiver (radio) can receive it. The design of the system has been broken down into subsections to make the complexity of each portion more manageable. The digital tuner interface is expected to be one of the most challenging parts to implement correctly. Implementing the interface of the LCD, PIC, and the tuner is a complex task. The circuit must be designed to tune in steps of 0.2 MHz with a lower limit of 87.7 MHz and an upper limit of 107.9 MHz as per FCC regulations. Figure 4-2 describes FM bandwidth allocation for two adjacent stations. The theory behind some of these subsections, block diagrams, and schematics will be presented and discussed in the following sections and illustrations.

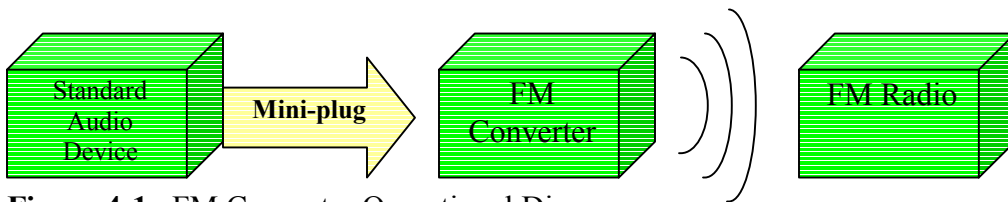

Figure 4-1. FM Converter Operational Diagram

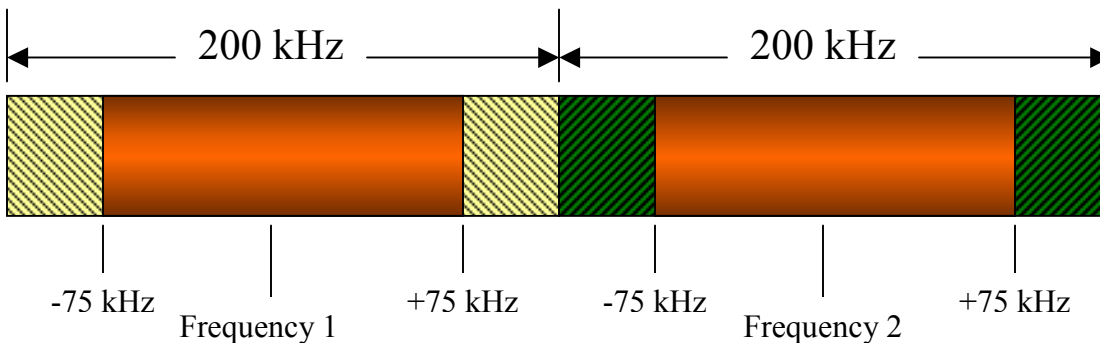

Figure 4-2. Commercial FM Bandwidth Allocation for Two Adjacent Stations

Our device will operate off the full range of the FCC designated FM spectrum. Other options considered included designing our device to operate on two to three adjacent frequencies, a fixed set of frequencies or operating in only a portion of the FM spectrum. Because this is a portable device that could potentially travel through different regions of the United States it must be able to change as different commercial signals become receivable.

Currently the FCC mandates that no two stations, with adjacent broadcasting frequency, may operate in the same town. However, this does not stop two stations with adjacent frequencies, in different towns, to be received in the same location. In essence the FCC does not set a commercial broadcasting range limit that would allow us to design a system that operates off two to three adjacent frequencies.

We feel that with a device that operates in the full FM spectrum, as opposed to a small range in the spectrum, would be more desirable to consumers. In some areas of the country the FM spectrum might be very crowded or noisy. There is no way to ensure that the any reduced range we design our device to operate in will be clear enough for our signal to be received.

4.1 THEORY OF OPERATION

The high level theory of operation for the FM converters seems simple. In abstract, its function is to convert a signal from an audio input to a broadcasted FM output. It seems simple until some of the actual objectives are examined more closely. When the goals of the device are studied in depth, it can be seen how complex its operation truly is. A large

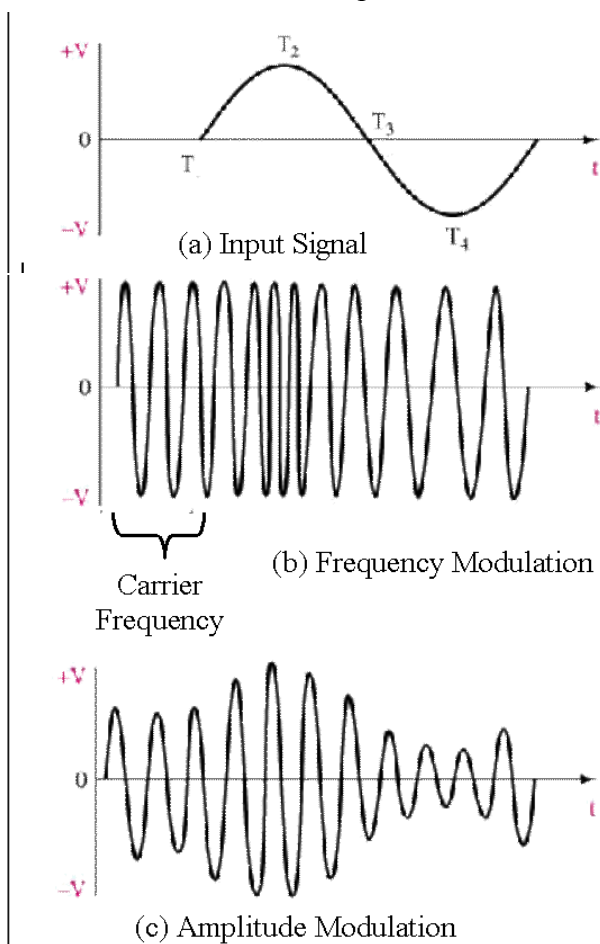

number of complex circuits have to work together for the desired operation to be achieved. The challenge does not stop with correct circuit operation. The device has to work properly in the packaging described in the design objectives. This presents many problems by itself. Putting a large number of components that close together in a small enclosure is sure to add even more difficulty and is sure to cause some variations in circuit outputs.

In our design we choose our design to utilize FM broadcasts over AM. FM was chosen because its signal is less susceptible to external noise sources. This is true because FM's

Figure 4.1-1. Picture courtesy of the University of Edinburgh

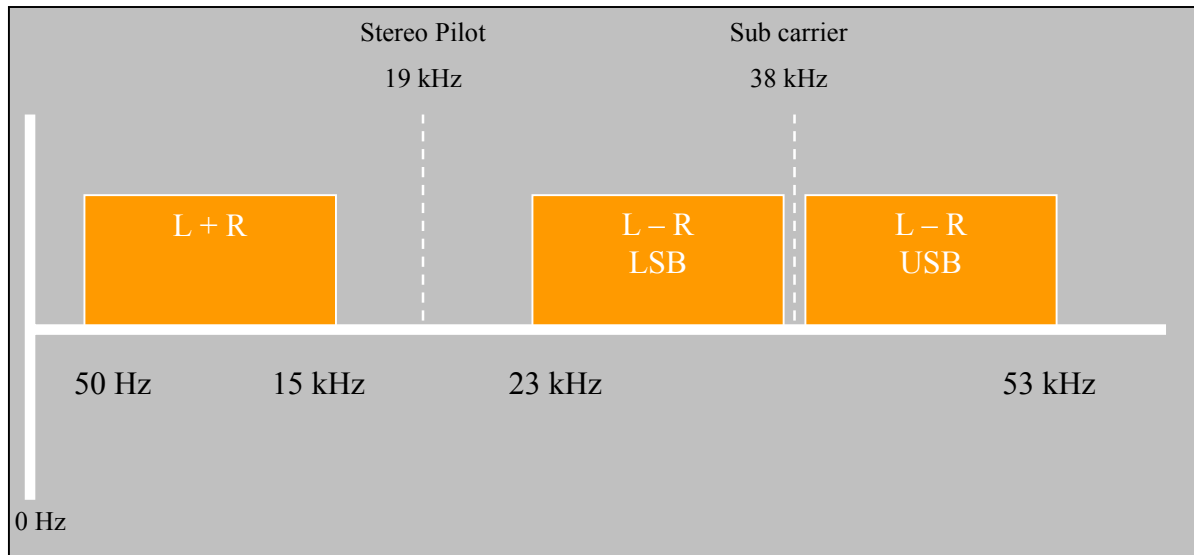

Figure 4.1-2. FM Base band

carrier signal changes in frequency as apposed to voltage modulation that occurs in AM broadcasts. Figure 4.1-1 (a), (b), & (c) gives an example of FM an AM signals. Fm also allows for a higher quality sound. It is easier to produce a more accurate signal with lower distortion. A drawback of FM is the increase in the power it takes to transmit, because FM has such high bandwidth requirement when compared to AM. Another drawback to transmitting FM is an increase in the complexity of the transmitter and receiver circuitry.

The FCC requires FM broadcasts to account for old style mono-radio and stereo radios. Although mono-radios are no longer produced and could presently be found in museums, when the FM broadcast switched to stereo the FCC wanted the mono-radios to stay compliant. The mono signal is broadcasted 50 Hz and 15 kHz range. Between 23 kHz and 53 kHz the stereo component of the signal of a modulated Left-Right can be found. Here a Left-Right signal operating between 50 Hz and 15 kHz is modulated with a 38 kHz carrier signal. After the modulation the signals bandwidth doubles and is centered around 38 kHz. There are actually two L-R signals on each side of the 38 kHz carrier signal. These two signals are mirrors of each other. The L-R modulated signal, the L+R mono-signal and a 19 kHz pilot signal are sent for the final modulation with the carrier frequency whose lower limit is 87.7 MHz and has an upper limit of 107.9 MHz. It is this final carrier frequency that is received by the receiver and subsequently decoded. Figure 4.1-2 illustrates the base band frequency spectrum described above (Note: The final carrier frequency is modulated with the spectrum shown below, creating sidebands at the operating frequency.)

The basic theory behind our frequency converter is shown in Figure 4.1-3. This is a block diagram that shows the basic modules needed to create an FM converter.

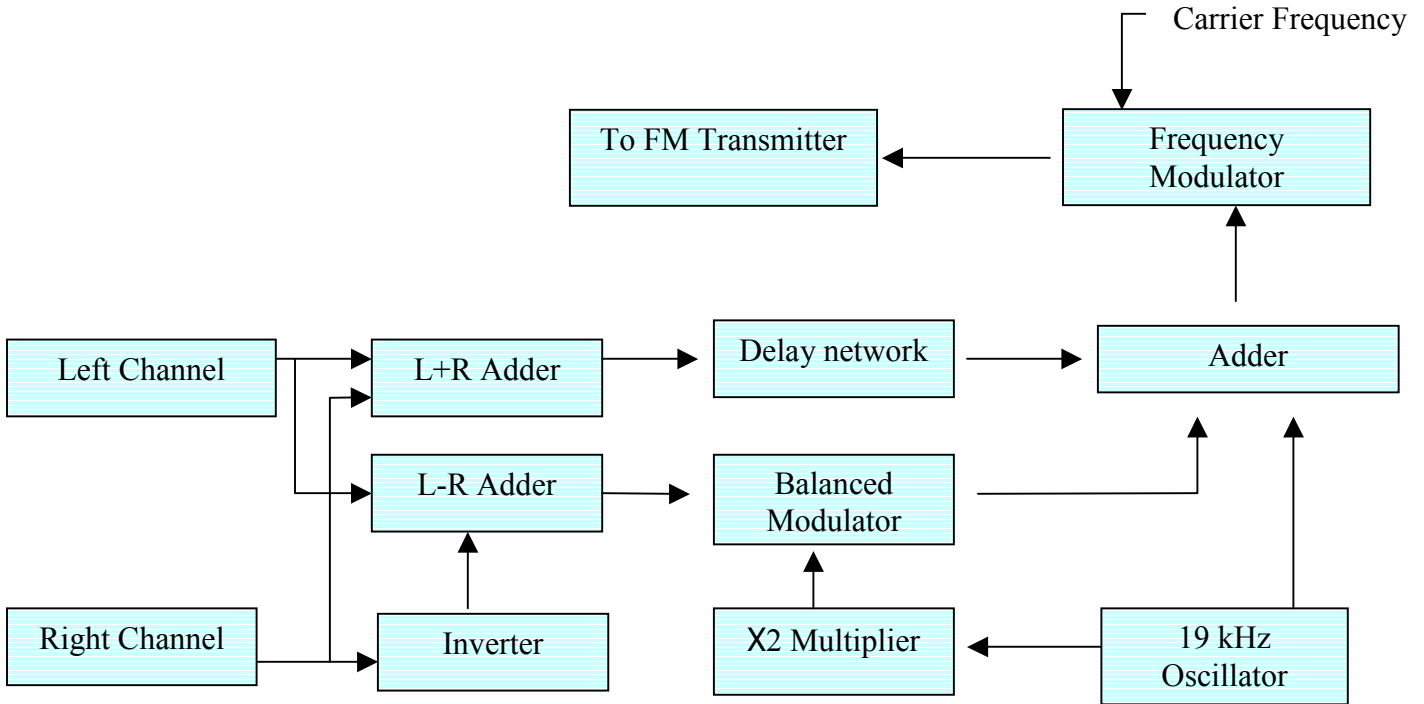

Figure 4.1-3. Block Diagram of Components to FM Converter

The first components the Left and Right stereo signal is the Adder. Here the signal is added to create a Left+Right signal, which is then sent to a delay network to account for the time it takes to modulate a signal. The next step in the conversion process is the right channel is sent to an inverter, this creates an inverted right signal. This is then sent to an Adder along with the left channel to create an effective Left-Right signal. The schematic for both adding circuits along with the inverter is shown in Figure 4.1-5.

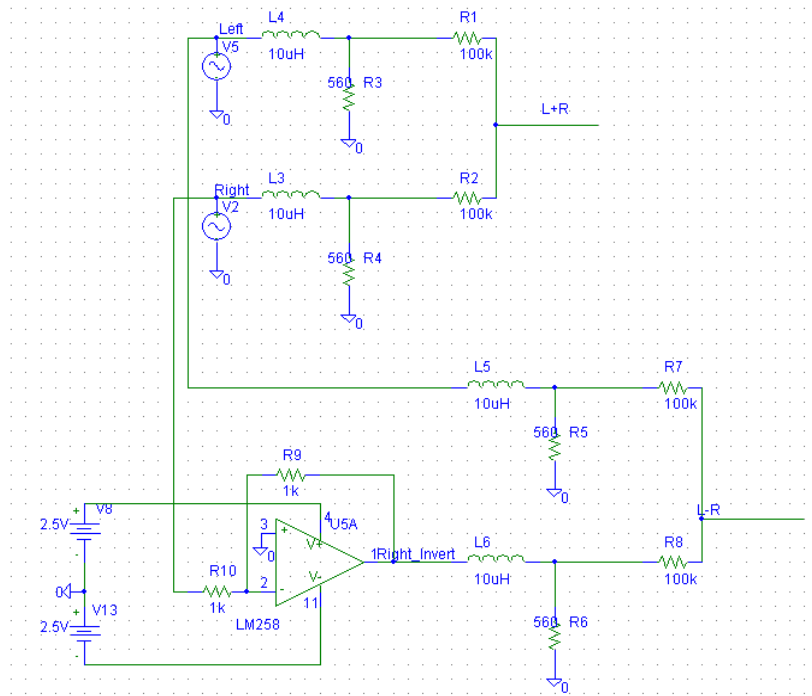

Figure 4.1-5. Schematic for Dual Adder Circuit

The Left-Right signal is

then sent to a modulator, which is then modulated with a sinusoidal pilot signal of 38 kHz. To achieve the 38 kHz signal a 19 kHz is sent through a frequency doubler. The diagram for the frequency doubler circuit is shown in Figure 4.1-5.

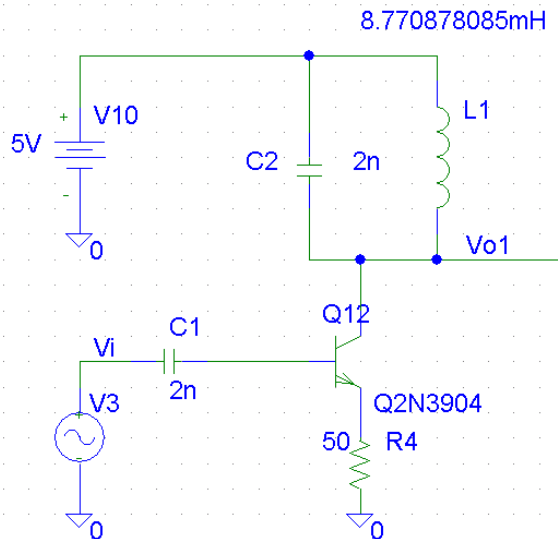

Figure 4.1-5. Schematic for Frequency

The signal from the modulator and the delay network is sent to another adder along with the pilot signal of 19 kHz. After the three signals are added together, the added signal goes through final modulation with the carrier frequency. Finally, that modulated signal is transmitted through the antenna.

4.2 SELECTION OF PARTS

Because the design constraints set for this system are quite ambitious, the parts selection process is tedious. Each selected part must meet all of the constraints for its

individual operation as well as not interfering with any other part in any way. Since this is a consumer electronic device, size, weight and cost are of great importance. Today's consumers want the smallest, lightest devices possible were miniaturization is the standard in such devices. In future developments, more integrated circuits could be used. This would allow the device to be even smaller and use less power.

4.2.1 PLL Frequency Synthesizer with Serial Interface

At the heart of the FM converter is the PLL. This component provides the carrier frequency that will be used to broadcast the converted signal to any FM receiver. The PLL that has been chosen is the MC145170-2 manufactured by Motorola. This chip was chosen because it operates in the frequency range that our design specifies, 40-160 MHz depending on the reference oscillator. Secondly, the MC145170-2 operates within the power requirements that our design will provide. It operates from 2.7-5.5V DC and dissipates 300mW during worst-case operation. What made this integrated circuit especially attractive is its ability to accurately divide the frequency such that it can be controlled in incremental steps by the micro-controller. This provides the device with the ability to use digital push-button style user interface. This will make tuning the device easier and give the user more feedback on its operation. The PLL stabilizes purpose is to stabilize and divide the carrier frequency. This will give a more consistent and higher quality output signal.

Since the device is portable and will be used in automotive applications, it is important that all components be able to withstand temperature extremes. The MC145170-2 is capable of operating in temperatures at 260° C for extended periods. This will more than

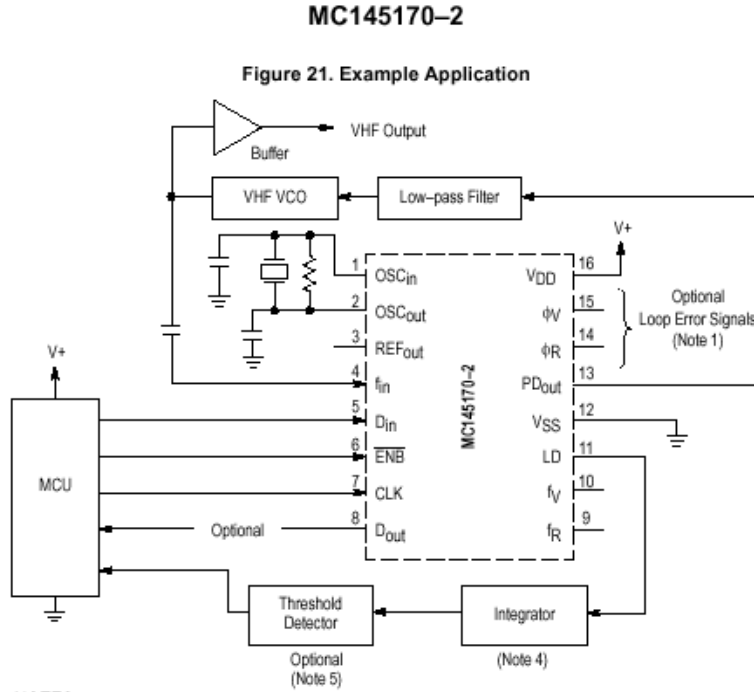

Figure 4.2.1-1: This diagram is presented courtesy of Motorola's information site

satisfy any extreme that will be encountered in normal automotive usage. One of the most important factors to consider in production device component is cost. The MC145170-2 has a per-unit cost of \$5.95 for prototype size orders. The per-unit cost for high-volume orders is approximately half of this amount. Size and weight are also important factors to consider. Since this is a consumer device, it must be easily transportable. This means keeping it as lightweight and small as possible. This chip is

well within the acceptable range of both categories called for in our design requirements. The dimensions of the unit for final production models are .2" x .177" x .047". This should not cause a problem with packaging size. Some helpful illustrations, schematics, diagrams, and design equations follow in this section. The block diagram for this unit is presented in Figure 4.2.1-1.

Other useful information is available online but diagrams require a large amount of document space and memory. They are left out for brevity.

4.2.2 Programmable Interface Controller

The component that will link the entire digital portion of the design is the programmable interface controller or PIC. In our design, the controller will be used to drive the PLL as well as the LCD. This type of IC will only be used for prototyping. For mass production, a more specialized and cheaper chip would be used. The PIC that has been chosen for our application is the PIC16F84. This particular component was chosen for several reasons. An attractive feature of this IC is the 1k FLASH programming capability. This will allow plenty of memory storage for the programs needed to control the other components. The program that will be used will be complex due to the multiple intricate circuits it will need to control. This PIC model has the number of pins that are needed for our interface as well. As with other components in the system, cost is a factor. Since this chip will only be used for prototyping and the most appropriate mass production chip is not chosen yet, it is difficult to project a per-unit cost. It will be much less than the unit

that is being used for the prototype. The per-unit cost of the prototype model, with the small order, is \$5.90. Again, this cost decreases substantially with higher volume orders.

Another feature about this type of PIC that makes it well suited for our design is the sleep mode it employs. This is a very desirable characteristic to possess for this project. Once the user has selected the desired operating frequency, the PIC essentially turns off. This will result in a dramatic reduction in power consumption. Decreased power consumption means increased battery life, which is attractive to the consumer because of the savings that result. The worst-case power dissipation of the unit is 500mW. This is acceptable for the requirements listed.

The voltage range for this device is 4 to 6V DC, which is compatible with the available sources in the system. As with the PLL the PIC16F84, must be resistant to temperature changes.

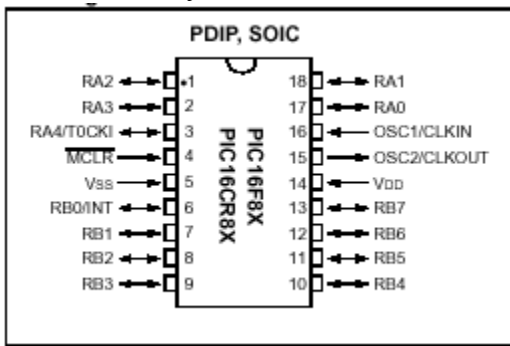

The maximum operating temperature is 125° C under bias. This is well in excess of standard automotive temperatures in extreme conditions. The size of the unit was also a consideration. The unit being used measures .299" x .462" x .104". This should not present a problem when incorporating it into the specified packaging. The pin diagram for the unit is presented in

Figure 4.2.2-1: Pin diagram for the PIC16F84. This diagram is presented courtesy of Jameco.

Other useful documents for this component are available online but as with the PLL they are omitted for brevity.

4.2.3 LCD

Along with being digitally tunable, another unique feature of the FM converter is that it will provide the user with a means of visually checking the operating frequency. This is a feature the consumer will find especially useful in automotive applications. When traveling through different regions of the country, different broadcast frequencies will be encountered. If the converter is operating on a frequency where there is also a strong broadcast transmission, undesirable operation could result. This occurrence is inevitable due to the large number of stations in operation. This is why the tuner is incorporated in the design of the system. This will allow the user to simply change stations should they encounter a strong signal on the frequency they are using. The LCD will enable the user to quickly and easily what frequency he or she is currently operating at or tuning in. Although it is not recommended that the user to tune the device while driving, it is certain that it will happen. Having an easy-to-read frequency display will make such a process safer than if he or she had to fumble with knobs not knowing where they were tuning the output frequency. The less time and effort a driver has to put into tuning our device, the better. That means less distraction from the road.

When choosing the LCD, many factors had to be considered. Size, cost, readability, readable angles, power usage, and many other variables were examined carefully. The component that was chosen was the AC-162AYILY. After careful consideration, this unit appeared to be the best suited for our application.

The AC-162A is a backlit display. This will allow the user to see the characters easily at night. Having this feature involves certain drawbacks. While the LCD is useful for low-light situations, it needs extra power to be able to do so. This extra power usage decreases battery life. Another drawback is that a bright light in an automobile cabin at night can be a dangerous distraction. To counteract these problems, the LCD will operate in a manner similar to most handheld cellular phones. When the unit is not being tuned, the backlight feature will be inactive. This will reduce the operating current by 70mA. Over time, this reduction in current will produce a substantial improvement in battery life. Not only will this feature make the unit cost less to operate, it will eliminate the nighttime distractions the unnecessary light would cause. The user will simply push one of the tuner buttons to illuminate the screen. Once lit, the screen will stay lit long enough to allow the user to leisurely tune the frequency he or she wants. Then, the light will turn off before it becomes a driving hazard. The times for the delay are not firmly set at present.

Features other than backlighting were also important in selecting an LCD. Size and weight were a major concern. There are a staggering variety of displays available. The font size of the unit had to be large enough for the user to see quickly and easily. However, the size of the entire unit could not exceed the packaging requirements for the system. The AC-162AYILY satisfied this requirement as well as any that were examined. The measurements of the chip are 85mm x 29.5mm x 14.5mm. The measurements of the actual display are 64mm x 17.2mm. This is by far the largest component in the design and requires the most careful consideration in selection. When setting the original size constraints on the system, the LCD was the primary factor in determining how large the

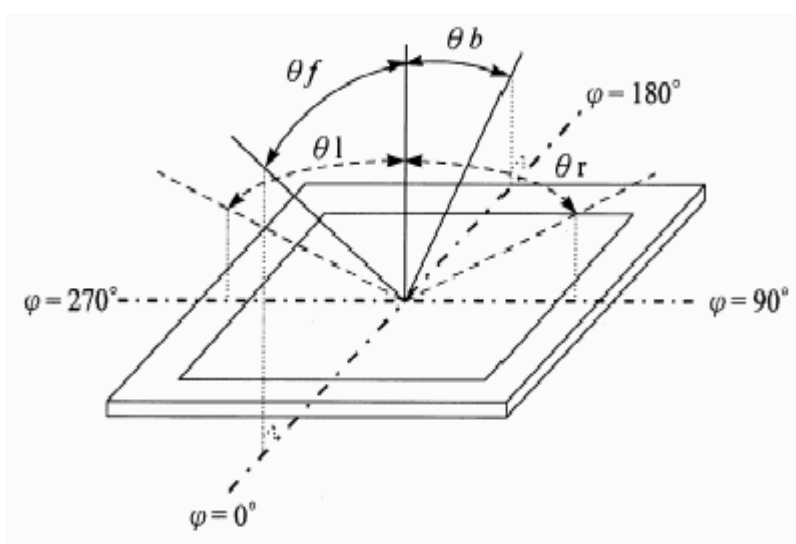

Figure 4.2.3-1: Viewing angles of LCD courtesy of

packaging would need to be. The weight of the system is also a size consideration. The AC-162AYILY is well within the system weight requirements.

Power requirements were a factor as well. The LED portion of the AC-162AYILY operates at 4V DC and 70mA. The display portion of the component operates from 2.7 to 5.5 V DC and uses 1.5mA (logic) and

variable current for contrast. This is within the power requirements of the system. For the size of the display on this unit, the power consumption is very competitive with those of other smaller units.

A very important characteristic of an LCD is the viewing angle. This refers to the angle made with reference to a line perpendicular to the display face. The bigger the viewing angle, the more easily the display can be read from abnormal angles. For the AC-162AYILY, the viewing angle is described as being $\theta_f=35^\circ, \theta_b=10^\circ, \theta_l=30^\circ, \theta_r=30^\circ$ as shown in figure 4.2.3-1.

As with all other components, cost plays a major role. The AC-162AYILY costs \$14.95 per unit for a prototype order. Like most other components, this number drops significantly when a large number of parts are ordered. The mass production cost of this component should be no more than half of the prototype cost based on consultations with sales representatives.

Durability is a problem with many displays. This is a source of concern since this unit will be operated in an automotive environment with temperature extremes. The AC-162AYILY is rated for operation at ambient temperature of 122° F for 96 hours. For non-operation, the AC-162AYILY is rated at 160° F for 96 hours. The temperature inside an automobile cabin can reach upwards of 140° in extreme conditions but this temperature is not sustained for a long enough period to cause a problem. From examining data sheets on various displays, the AC-162AYILY looks to be one of the most shock-resistant choices available as well. The user will test its durability on a daily basis.

4.2.4 MODULATOR

The modulator is the heart of the FM Converter. It is the portion of the network that actually converts the audio signal into a modulated FM signal. The theory behind modulation is discussed in the Theory of Operation section of this document. The process of modulation places the information carried by the audio input onto the carrier frequency for transmission. Since the modulator is the most important part of the device, it was designed first. Other circuit elements were designed to function with the existing modulator.

Several types of modulators were examined for use with the converter. The original design constraint involved using a PLL to produce full-range tunability. The modulator used for this setup was redesigned when the PLL was omitted from the circuit. The PLL was omitted after significant difficulty was encountered with getting the VCO to respond properly.

One type of modulator considered for the converter is shown in Figure 4.2.4-1.

This type of modulator uses a crystal oscillator. Many of the modulator configurations considered for the device used oscillators like these. To use crystal oscillators in the FM

Converter would involve switching among the different oscillators used. Tuning the device would be accomplished by selecting a different oscillator to broadcast at a different frequency.

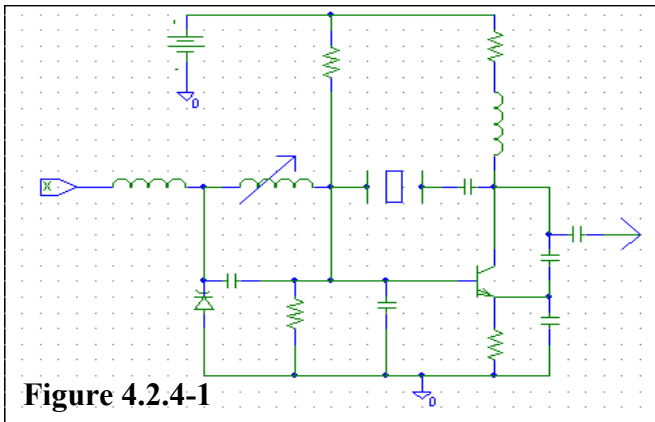

This option was ruled out for several reasons. It is not desirable to switch between different oscillators. The FM Converter is packaged in a small enclosure. Having different oscillators operating simultaneously would generate stray electromagnetic fields that could cause harmful interference inside the enclosure. To eliminate this problem power to the oscillators would need to be

removed for each switching operation.

Another undesirable feature of the crystal oscillator is the lack of frequency adjustment. It is difficult to tune such a device to frequencies other than the specified one. Because this was a prototype-packaged unit, this type of tunability was desired. Frequency drift is inevitable with radio circuits. Packaging these circuits can compound this drift. Having different oscillators in close proximity would likely generate frequency shifting that could not be counteracted by fine-tuning the device.

The circuit that chosen for the modulator is an adaptation of a standard transistor modulator. The carrier frequency is chosen by producing resonance between inductances and capacitances. Using a circuit like this has many benefits for the applications needed for the FM Converter. Because of the inevitable frequency drift discussed above, it is very desirable to have as many tunable components as possible. Using tunable

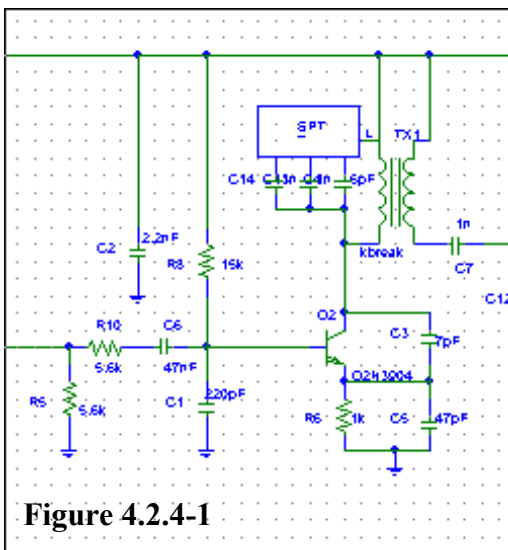

inductances and capacitances allowed for a much greater tuning range. In addition, having only one oscillating circuit minimizes the generation of stray electromagnetic fields. With the strict packaging guidelines, any undesired electromagnetic generation could cause significant interference. The basic circuit diagram of the modulator is shown in the illustration below.

The inductance used in the converter is shown in the schematic as a transformer. This is not an accurate depiction of the inductor used. The inductance used is a five-pin coil type variable inductor. It operates across much of the microhenry range. Variable inductances in this

range are not easy to find. This component drove the selection of the capacitances used for tuning.

The capacitances are tunable as well. Having tunability on both components allows for adjustment either for the whole range of channels or just for one of the channels. If all channels are off by the same amount, the inductance can be adjusted. However, if only one channel is improperly tuned, the capacitance for that channel can be adjusted individually. A three position rotary switch is used to switch between the capacitances. When switching occurs, a signal is sent to the LCD that prompts a change in the frequency displayed.

Inductances in this range are not easily found. No model files exist to represent the coil inductance used in the circuit. This lack of simulation caused difficulty when testing the hardware output. There was no simulated output to reference the hardware signal to. Standard inductances were used to model the coil inductor but they did not produce proper results for any of the scenarios tested. Other circuit components for this network are standard discrete components. The transistor used for this circuit (a TO-92, 9018) was chosen for availability and speed.

The only problems evident with modulation were caused by its location relative to the LCD network. Improper shielding allowed interference from the LCD to become noticeable on the audio output. This problem could be corrected with better shielding. The interference is not caused by the modulator; it is only received by it.

This modulator works well for the converter. The tunability of multiple components allows for compensation for the frequency shift caused by component proximity. Despite the undesirable tones caused by the LCD interference, the audio quality produced is very good. Audio output of the circuit is shown in the input vs. output section of this document.

4.2.5 PRE-EMPHASIS

The pre-emphasis portion of the device is the first network that the audio input signal will pass through upon entering the FM Converter. The pre-emphasis network performs multiple functions. Pre-emphasis processes input audio signal and converts it into a form suitable for input the modulator. The pre-emphasis section of the FM Converter was designed to function properly with the modulator.

Audio signals from RCA and mini-plug outputs can produce voltages over four volts. This is far too high to use for the bias voltage of the transistor in the modulator. Voltages in the millivolt range are required for this. Therefore, one of the function of the pre-emphasis network is to reduce the voltage of the input signal to make them usable by the modulator. The voltage divider network in the circuit shown below performs this function. The pre-emphasis network used for the converter is shown below:

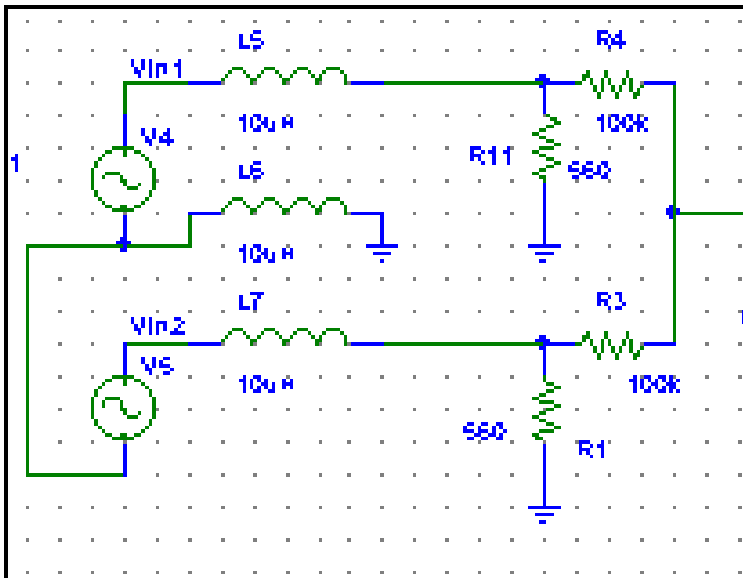

Figure 4.2.5-1

Another function of the pre-emphasis network is to condition the signal for modulation to help prevent distortion. The amplitude of the higher frequency signals is boosted. This helps to increase the signal to noise ratio. The demodulator of the receiver counteracts these effects as well as canceling some of the low-frequency noise created by transmission.

This portion of the circuit also performs an adding function. The input signals for this circuit are the left and right audio outputs from the CD player, mp3 player, etc. These signals are summed.

The following illustration shows a PSPICE simulation of this circuit using a 2 kHz sinusoidal input for the left channel and a 1.2 kHz input for the right channel.

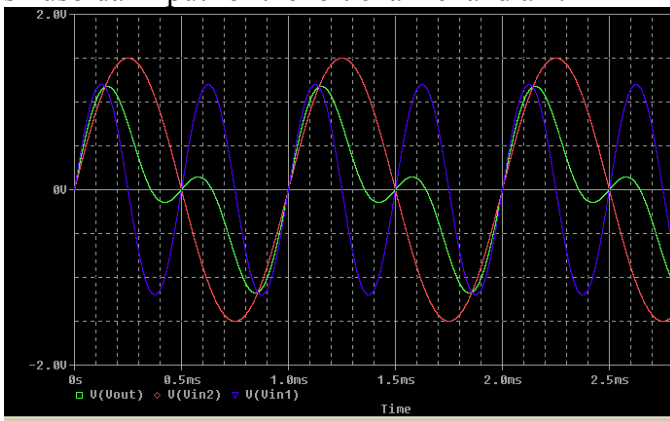

Figure 4.2.5-2

The summing function of the pre-emphasis is easily observable from the illustration. This simulation was compared to hardware output once the packaged product was finished. The output is shown in the illustration below.

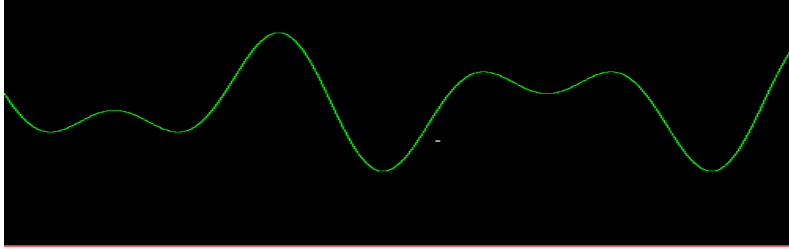

Figure 4.2.5-3

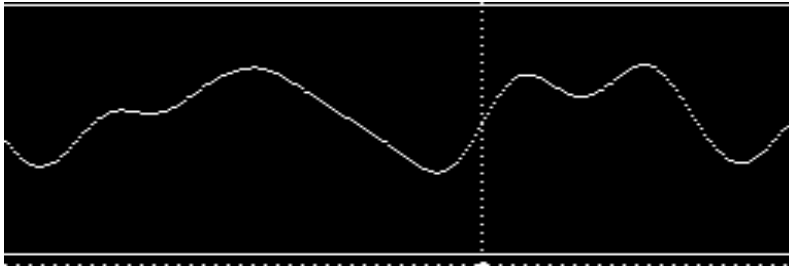

Figure 4.2.5-3

The top waveform is the PSPICE simulation output of the pre-emphasis network. The bottom waveform is the hardware output of the packaged product. The hardware output has some observable distortion. This is primarily caused by the 1.2 kHz interference caused by the LCD. For this waveform, this interference signal was actually used as an input. This signal changed frequency wildly. This produced the shift seen in the above waveforms.

All components used in this network are standard discrete components. The summing function of this network performed very well. Packaging the input signal properly for modulation greatly affects the output sound quality. These hardware results show that this section of the device is performing as it should.

4.2.6 ANTENNA AND AMPLIFICATION NETWORK

The amplifier section of the converter is the simplest portion of the circuit. It is a simple transistor amplifier. The input audio signals were significantly reduced for modulation. The modulated signal must be amplified again for transmission.

This portion of the converter was designed around the modulator as well. An appropriate output network had to be designed to amplify and transmit the signal produced by the modulator. This is done with standard discrete parts. The same transistor used in the modulator is used for this transmitter as well. Its high speed and low noise emission make it a good choice. The configuration of the circuit is a basic transistor amplifier. The schematic of the circuit is shown below.

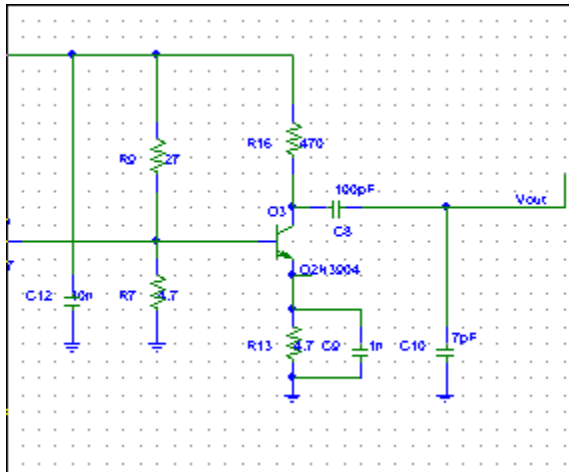

The output of the transmitter is connected to a flexible, movable antenna mounted on the side of the enclosure. This is denoted by the Vout node on the illustration above.

4.2.7 MINI PLUG INPUTS AND INTERFACE CORD

Mini-plugs were chosen for the audio input for the device. Many factors were considered before arriving at this decision. There was a substantial debate between the advantages of mini-plugs versus RCA inputs. By using RCA inputs, the user would be able to interface either type of device with the converter. The cost of replacing RCA cords is low and they are available in a wide variety of lengths. The downside to RCA inputs is durability. RCA plugs are notorious for flaring out on the ends of the connectors. This leads to poor connections and results in static or unacceptable sound quality.

Mini-plugs are smaller, require only one connection, and are more durable. The cost of the female end of the connection (which will be mounted in the side of the converter) is approximately 30¢ per-unit for prototype volume and less than 20¢ per-unit for mass production volume. The biggest advantage that mini plugs offer over RCA jacks is improved durability. There are no metal shields on the male connector to bend or break. In addition, the jack that is actually mounted on the unit is less obtrusive than that of RCA plugs. An RCA connection requires two externally mounted female plugs, which are prone to damage themselves. Additional mounting holes and materials drive production cost up, which is a major concern in a system like this. The user will still be able to use RCA inputs by using an inexpensive adapter cord. By doing this, the user essentially gets the best of both worlds. The versatility of the RCA jacks is combined with the durability and convenience of the mini-plug connection. As an additional benefit, the production cost of the unit can be kept lower.

4.2.8 POWER SOURCE

The current power source that is being implemented is 4 AA batteries. AA batteries offer many advantages. They are small yet they provide very long life. Standard alkaline AA batteries offer a rating of 2850mAh. This is far superior than that of AAA which is 1150mAh yet much smaller than bulky, bigger batteries. AA batteries are commonly used, widely

available, and inexpensive compared to other options. This makes them a very attractive power source.

The current number of four batteries is needed to drive all of chips that will be incorporated in the system design including LCD and oscillator. A stable 5V source is desirable for such operation. Future goals are to be able to operate the converter using only two batteries. This will most likely entail some component redesign. Some component choices may have to be changed for lower operating voltage options.

The power supply will not just consist of batteries and contacts. Voltage regulation is also needed for the system. The regulator that will be used is the UA7805. This is a voltage regulator chip that will produce the stable output needed. This chip is designed for this type of application. It is a 5V DC and up to 1A regulator. This will ensure that no overload occurs and that it can handle the heat of automotive applications. The cost of this component for prototype orders is 29¢. This goes down to 20¢ for large orders. The size of the unit as well as weight is well within acceptable ranges. To reduce power consumption by the unit the voltage input to the regulator will be stepped down. This will reduce the amount of power that will need to be dissipated. By reducing the power dissipation, battery life is extended, internal heat generation is reduced, and voltage requirements are not compromised. Using the step-down network is a much more efficient means of voltage reduction than using the regulator.

4.2.9 FREQUENCY MULTIPLICATION

A frequency multiplication network must be included in the system. This is needed to obtain the 38kHz frequency used in stereo generation. A schematic for this network can be seen in Figure 4.1-5. For the network shown, design equations were used to solve for component values

$$f_c = \frac{1}{2\pi\sqrt{LC}} \text{ Solves for output frequency}$$

$$f_p = 19\text{kHz}$$

$$f_c = 2 * f_p = 38\text{kHz}$$

The values used for this simulation were $C = 2 \text{ nF}$ and $L = 8.77 \text{ mH}$. The reason for generating this 38kHz signal is explained in detail in the theory of operation section. This network will be composed of discrete components whose values are not firmly set at present. Cost of the components in this network will be negligible in comparison to other more costly components. Likewise, size and weight of the necessary components are also acceptable for design constraints.

4.2.10 ADDER NETWORK

The adder and dual adder networks will also be composed of discrete components. Schematics for the dual adder are shown in Figure 4.1-3. The single adder schematic is shown below in Figure 4.2.9-1.

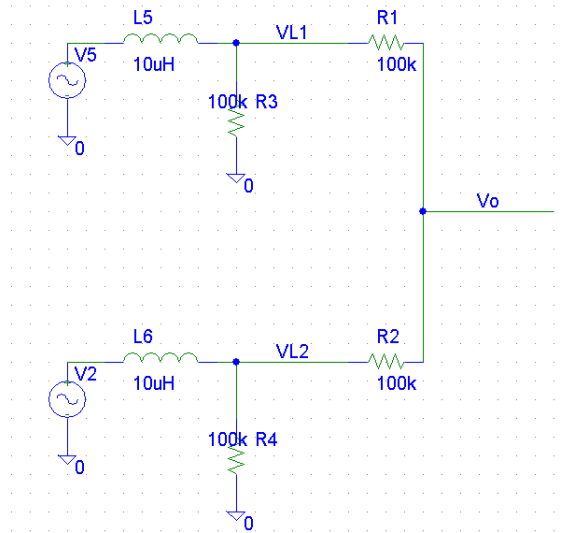

Figure 4.2.9-1. Single adder Network

As with other networks comprised of discrete components, size, weight, and cost are all well within the specified acceptable range. As before, component values are not firmly set. Some adjustment will be made when the hardware is fabricated and integrated into the entire network.

4.2.11 SUBTRACTOR NETWORK

The subtractor network will be composed of discrete components as well. The schematic is shown in the bottom half of Figure 4.1-3. As with other sections of the design, component costs for this section are minimal compared to other more expensive components. Size and weight will also be small in reference to larger components. The values listed on components in the simulation diagram are not final values. Along with other networks components, these values are subject to change during implementation to achieve the desired output.

4.2.12 TOTAL POWER CONSUMPTION

Device	Current Consumption Scenarios		
	Typical (mA)	Worst Case (mA)	Best Case (mA)
PIC	5	10	0.28
PLL	30	30	30
LCD	1	1.5	1.0
LED	0	500	0
Total	36	541.5	31.28

4.3 FREQUENCY SELECTION

The choice of which frequencies would be used for transmission was quite difficult. Many factors had to be carefully considered before arriving at a final decision. The original goal was to be able to use the entire FM band to give the user the most choices possible. To accomplish this goal, a phase-locked loop or PLL would be needed. Significant difficulties hampered progress in this area. Despite months of work and considerable progress, a different option was chosen.

The revised plan for frequency selection gave the user three frequencies to choose among. Although this may seem to be a major shortcoming, it does not affect the functionality of the device significantly. Although the FM Converter broadcasts a low-power signal, its proximity to the receive antenna on an FM radio compensates. The FCC limits non-licensed broadcasts on the FM band to less than 300 $\mu\text{V}/\text{m}$ at three meters. This is a strict limitation but one that can be overcome with close proximity between the desired transmitter and receiver. When a radio station transmits a signal, the energy emitted from the antenna is scattered. The scattering pattern depends on the type of transmission network used for the station. For any radio transmission of non-trivial distance, the amount of transmitted power that actually makes it to the receiver is miniscule compared to the transmitted amount. This phenomenon is what the FM Converter possible. It is possible to broadcast a legal signal and still get adequate reception quality; even when there is another station broadcasting on the desired frequency.

For this reason, the selection of three channels for the user is adequate to provide a clear signal. The full-range tunability was a goal set primarily for convenience and marketability. The full-range tunable option would not be any more functional than the three-channel version. The proximity of the transmitter makes the difference. As long as the converter's signal is strong enough at the receiver's antenna to overpower the interfering radio station's signal, a good signal is still attainable.

Not having the full range tunability did present a substantial challenge. With three frequencies available for transmission, the choice of which three to use was given great consideration. Since all FM stations have broadcasts on them in some locations, there are no open locations to choose from. Obviously, the next best solution is to find three frequencies that will never have a signal on all three in the same location.

Finding three stations like this is not an easy task. To complicate matters even more, new stations can come online and make old choices invalid. The best way to solve this problem is to use stations that are regulated either by distance, power, or frequency spacing by the FCC. The FCC regulates the distance between transmissions on the same frequency, adjacent frequencies (200 kHz separation), and 400 kHz to 600 kHz separations in different classes. Every frequency separation above these are regulated to the same, comparatively small, separation distance requirements. The table below shows a compressed version of the one found on the FCC's website at:

<http://www.fcc.gov/mmb/asd/spacing/73207.html>. For brevity, and clarity, the entire contents of the table are not shown. Selected samples from each antenna classification were chosen.

Station Type	Same Frequency	Adjacent Frequency (200 kHz Separation)	2nd & 3rd Adjacent Frequency (400 & 600 kHz Separation)	All Stations
A to A (Weakest)	115 Km	72 Km	31 Km	10 Km
B to B (Mid-Range)	241 Km	169 Km	74 Km	20 Km
C to C (Strongest)	290 Km	241 Km	105 Km	48 Km

Table 4.3

By using the table, it is easy to see that the closer the channels are with respect to frequency, the further they are required to be from one another with respect to distance. Past 600 kHz separation (.6 MHz) which is the difference between 91.1 MHz and 91.7 MHz on a radio tuner, the requirements become standard no matter how far the channels are separated with respect to frequency.

The logical choice, then, is to use three adjacent frequencies for transmission. Doing so does not guarantee that there will always be one of the three channels open no matter where the user takes the FM Converter; it only guarantees the highest probability. By using adjacent frequencies, the user is assured that if there is interference on the channel they are on, the next channel up or down has the farthest regulated distance between transmitters. Even in cases where the user is between towers, or in a “triangle” of the three towers, the regulated distances are enough to ensure sufficient distances.

To decide on which three adjacent frequencies to use, several information sources were consulted. The website: www.radio-locator.com was used extensively. This website uses a database of all registered broadcast stations in the United States and Canada. Radio stations can be looked up by frequency, format, location, etc. This was very useful in determining the number of stations on a certain frequency.

After consulting these sources, the choice of 88.1-88.5 MHz was made. There is little noticeable distance between the number of stations on these frequencies. However, the format of these stations is either public radio or religious broadcasting. Through investigation of different ranges in the lower frequencies, these were determined to have the lowest power output. In general, the transmission power of stations in the lower

frequency range of the FM band is not as high as those in the middle and upper ranges. All of these reasons led to the choice of 88.1-88.5 MHz. The user should be able to operate interference free as a result.

5. TEST SPECIFICATION

Design Constraints	Pspice	Matlab	Performance Testing **	Oscilloscope **
Radio Frequency			√	√
Signal Strength		√		√
Operating Voltage	√			√
Antenna Efficiency				√
Signal to Noise Ratio		√		√
Reliability			√	

Table 1. Projected test operations.

** All tests performed in indicated columns will be performed after the device is built.

6. TEST CERTIFICATION

The output for the adder circuit (refer to Figure 4.2.9-1) is shown below in Figure 6-1 –a, -b. We designed our adder circuit to use as few components as possible. This helps keep our costs as low as possible. Hope fully it will also increase the batteries effective life when it is applied to our full design. The inputs (Figure 6-1-a) were set for frequencies between 12 kHz and 15 kHz. These are the upper frequency limits of audible sound and similar to the real life conditions the circuit will face. The produced output (Figure 6-1-b) is a clear, stable signal. This output indicates that any distortion to the signal will be minimal if not completely immeasurable. This will help us achieve our signal to noise ratio goal of a range between 50 dB and 90 dB.

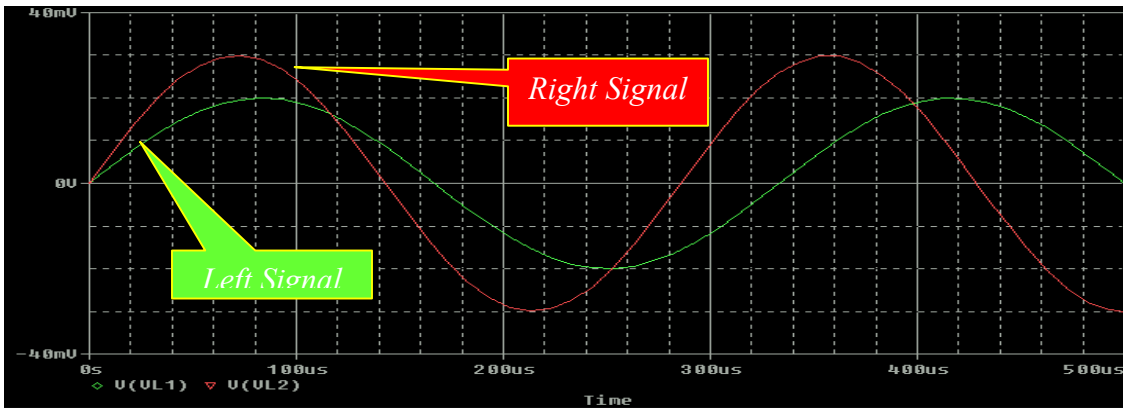

Figure 6-1-a. Input for adder schematic (Figure 4.2.9-1)

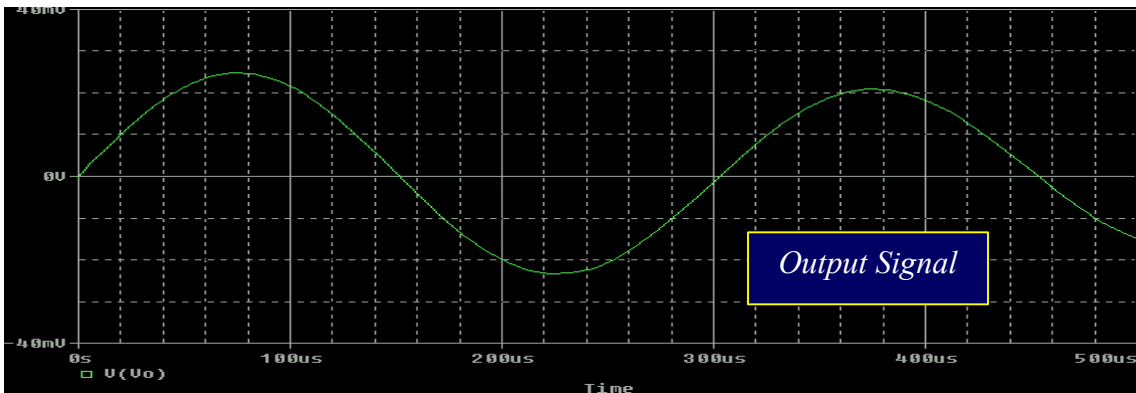

Figure 6-1-b. Output for adder schematic (Figure 4.2.9-1)

The output shown in Figures 6-2 –a, -b, -c, & -d correspond to the schematic shown in Figure 4.1-5. The op-amp used in the inverter configuration is an LM258. Through our research we have concluded that this particular op-amp suits our needs for the circuit as a whole. This op-amp will operate off of a minimum of 3.0 V and will also behave correctly in the frequency ranges normally associated with FM transmission. In this particular configuration the op-amp is powered off of a 5 V source. This is also within our power specification limit of 6 V. As shown in Figure 6-2-b the inverted right signal appears to be an exact mirror of the right channel input. Figure 6-2-d displays the output

of the dual adder circuit. Through visual inspection this signal appears to be a clean noise free signal, which is of great importance when trying to preserve signal clarity. Again we feel that the design of this circuit uses as few parts as possible, to drive costs down and to keep the physical packaging down to our specifications of 5" x 5" x 3".

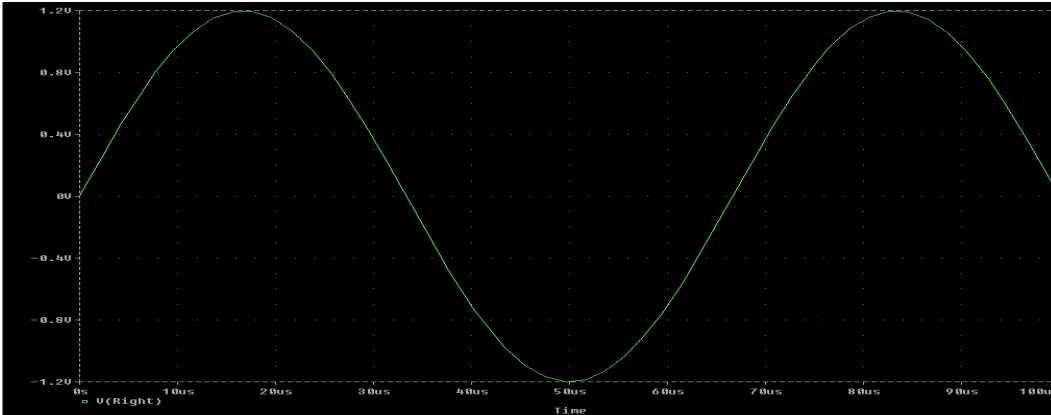

Figure 6-2-a. Right Signal Input

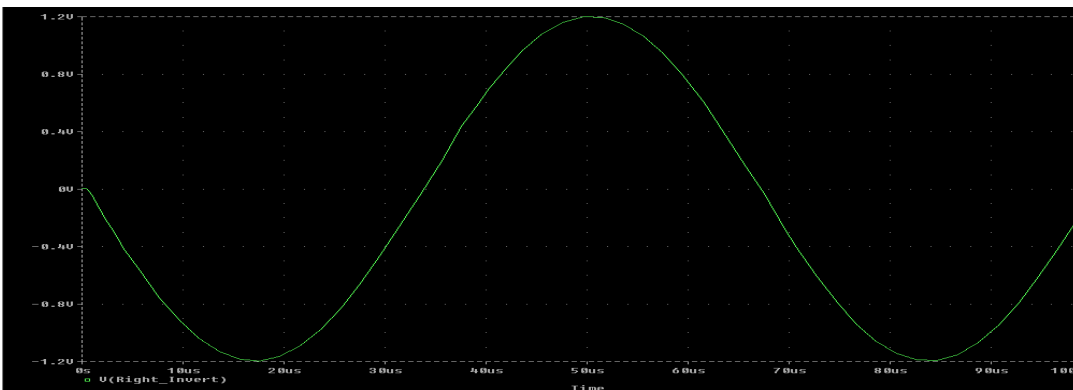

Figure 6-2-b. Inverted Right Signal Output

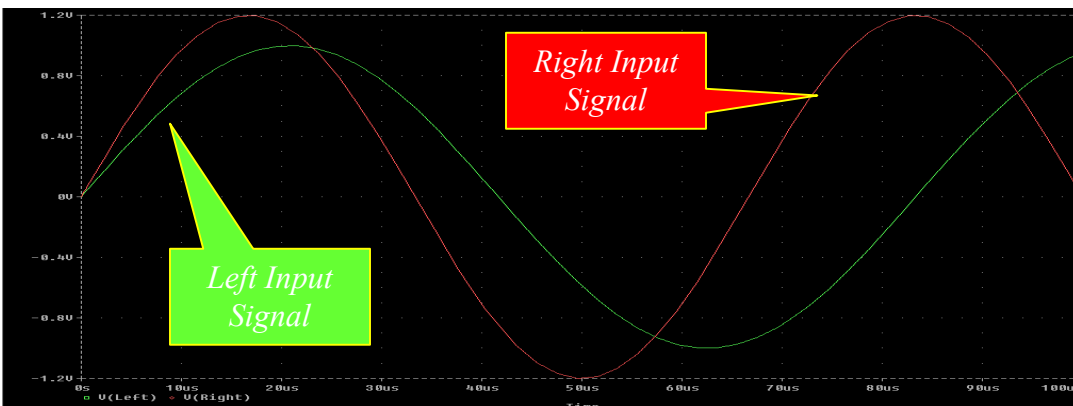

Figure 6-2-c. Left & Right Channel Input

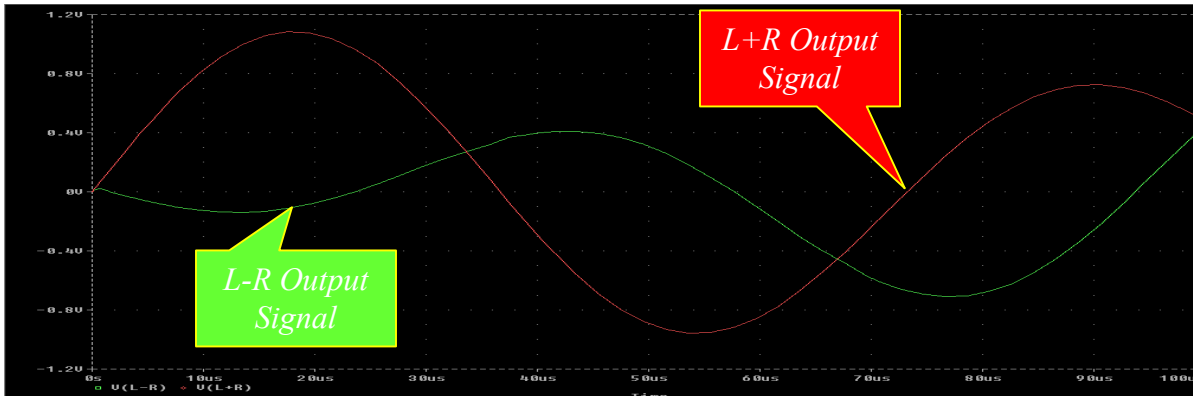

Figure 6-2-d. Left-Right & Left+Right Signal Output

Figure 6-3 –a, -b, -c describes the output from our frequency doubler circuit shown in Figure 4.1-5. The circuit takes advantage of a 5 V source in order to put the transistor in a forward bias active state. The 5 V source could be reduced if it is needed however it is also within our 6 V power requirement. The circuit shown in Figure 6-3-b produces a clean signal shown with no visible spikes or noise. The Fourier analysis of the input and output signal is shown in Figure 6-3-c. This chart shows the frequency at which the input signal and output signal is operating, which is 19 kHz and 38 kHz respectively. This chart is shown on a logarithmic scale and appears to have a fairly clear output signal at the 2nd Harmonic.

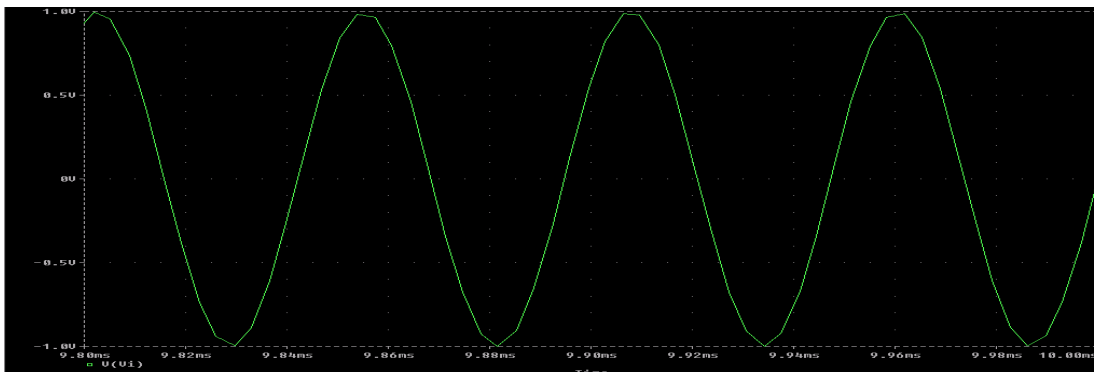

Figure 6-3-a. 19 kHz Input Signal

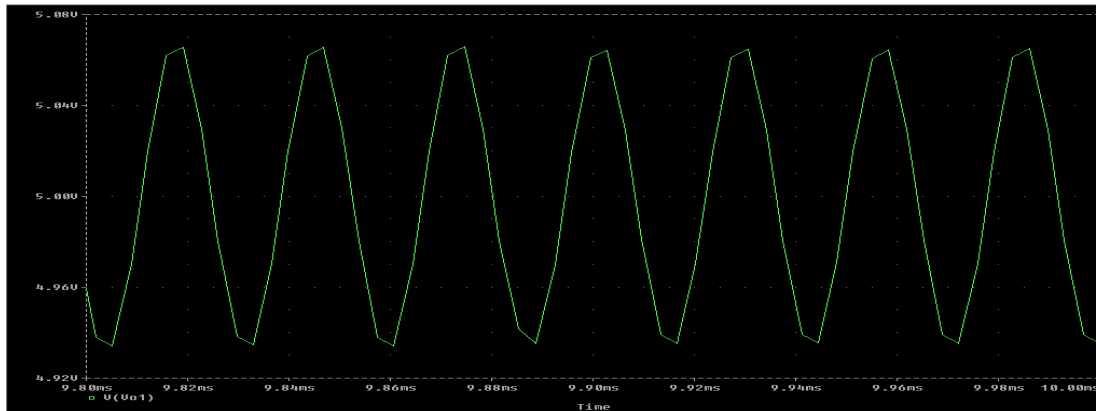

Figure 6-3-b. 38 kHz Output Signal

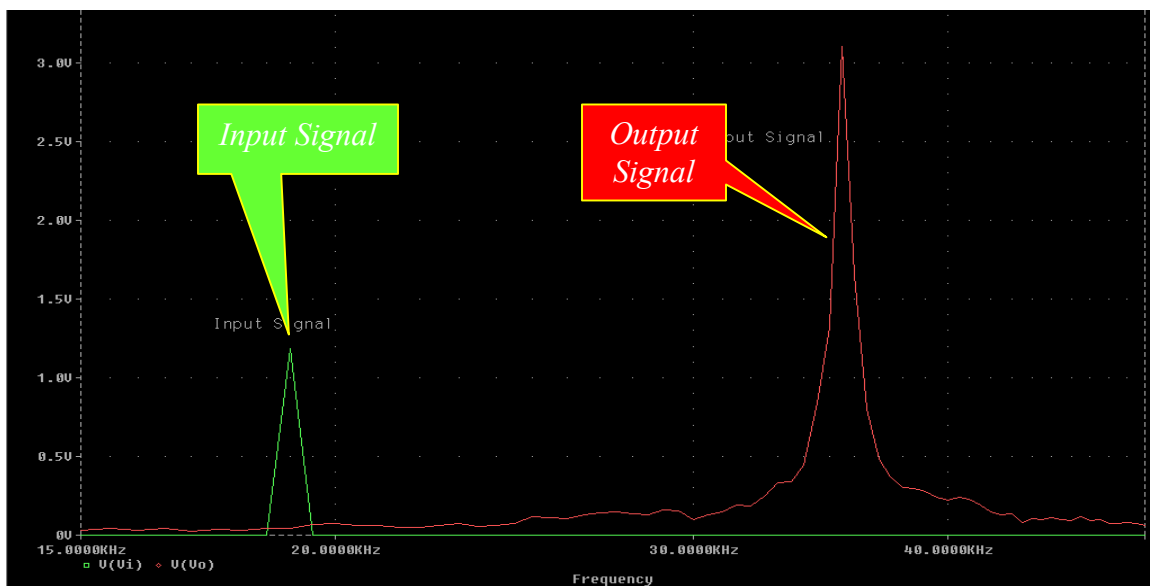

Figure 6-3-c. Fourier Analysis of Input & Output Signal

7. SUMMARY

A tremendous amount of work has been accomplished during the first few months of the design process. It has been amazing to see the accomplishments take place. Progress is mostly on schedule at present. Some areas are completely on track while others are somewhat behind schedule. Signal input and conversion has seen substantial development. Many of the independent circuits have been implemented and simulated with acceptable results. Due to PSPICE node limitations, as well as other difficulties, the complete system has not been simulated. With the full versions of different simulation software packages recently made available, these types of problems should be corrected soon. Antenna and output amplification will have more attention focused on them in the near future. These system components are important but depend on correct output from previous circuits.

Though a great deal of progress has been made, much work still needs to be done. Simulating a circuit in an ideal environment such as PSPICE is often far from the results seen in actual implementation. With a system like the FM converter, many changes are expected when the circuit is placed into its production style packaging. Everything from frequency drift to audio distortion can and probably will occur. These will be formidable obstacles to overcome. Working through difficulties like these will be both challenging and rewarding. The next few months will no doubt prove to be an exciting and possibly frustrating time. It will be an experience that will be beneficial in all future design ventures.

This LCD will work well with other system components that are being used. The PIC that was chosen will be used to drive the LCD output. This combination should work well in conjunction with the PLL.

8. FUTURE WORK

Over the first few months of the design experience, many valuable skills have been developed. The importance of careful planning and evaluation of alternatives has proven to be of utmost importance. Through first-hand experience, it has been observed that hastily made decisions on parts selection, testing, or simulation procedure cost even more time than if the alternative had been evaluated completely in the beginning. Several cases of this proved to be costly in the early design stages. There were instances where a portion of the project was researched and even simulated only to find out later that not only were the results erroneous but the circuit itself was not correct. By experiencing these inconveniences, all team members encountered the frustration that goes along with them. These experiences will no doubt prove beneficial in future design endeavors.

The FM converter project has been more difficult than originally thought. Initially, the design was going to be much simpler than what it has grown into. The objectives that are set currently are quite ambitious. The full-range digital tuner was not part of the primary concept. It was integrated into the system after helpful suggestions from others. This is a unique and helpful feature for the user. Other features were also added during the first few months. While these features are a welcomed benefit for the user, they do present considerable design challenges. Getting the digital tuner and LCD output fully functional is a daunting task. Many circuits must work together flawlessly to produce the desired output. Not only must the circuits function correctly both independently and collectively, they must do so in the packaging specified. This will require a great deal of time and effort.

Another portion of the design that has not received as much attention as others is the antenna. Until now, the emphasis has been on getting the desired output from the individual circuits. The converter must be matched with the appropriate amplification system and antenna to have the desired range and clarity. FCC regulations play a major role in determining how much power will be output by the system and what antenna will be used.

Future enhancements for the system will be somewhat limited. The FCC sets strict guidelines on transmission power. It is expected that this will be the primary area users will want to enhance. Since transmission power is directly related to musical quality, many users will desire to increase output power. The purpose of this device is not to provide the highest quality listening experience available. The signal quality of this device is expected to be similar to that of a standard FM broadcast station. What our device offers is versatility and portability. It can be taken anywhere and used with virtually anything. While it may not provide the best sound, it will more than make up for it in other areas.

Other areas lend themselves to improvements as well. Smaller, lighter devices are always in demand. The production model of such a device would no doubt be smaller and lighter than what the first prototype will be. Many of the involved circuits could be implemented using integrated circuits rather than discrete components. This would mean smaller, lighter circuits, which would also be more resistant to outside variables such as heat or humidity. Future improvements will become more evident as the prototype becomes more functional. Small flaws and improvement opportunities are more easily noticed with a working model.

9. GOALS VS. RESULTS

This section will compare the design constraints set forth in the first semester to the results obtained in actual working hardware. Most constraints were met, but some could not be fulfilled. All of the stereo sections were not met. The stereo section of the project was done in parallel with the design of the other components. This proved to be very helpful when all of the difficulty with stereo arose. Implementing parallel design principles allowed completion of the primary part of the project while parts were not fully functional.

9.1 Cost:

The estimated consumer retail cost of the converter is thirty dollars. To arrive at the retail price, this information was used along with a consumer survey asking various prospective customers what they would be willing to pay for such a device along with other questions. The PIC, LCD, and PCB cost was a significant factor. These components were more expensive than the other electronic components but are still low-cost items. The total component and fabrication cost was calculated to be \$86. The total production cost, estimated based on buying in large quantities, is \$20. This design constraint was satisfied in both aspects.

9.2 Power:

The device operates using four AA batteries. Other power options will be available to the user. Six-volt DC adapters can be purchased separately and used to power the converter using a 120V AC source. Six-volt adapters for cigarette lighter sources can also be

purchased. Because of the ability to use the device with batteries, the power consumption of the device was kept to a minimum to maximize battery life. Under normal operation, the current use is only 28 mA. With the backlit feature of the LCD on, the current use is 118 mA. AA batteries were chosen because of their long battery life (approximately 2850 mAh rated capacity for 25 mA constant drain). The worst-case battery life, with the LCD constantly on, is 89 hours. Operation without the LCD on has a best-case battery life of 407 hours. Under normal use, with the LCD on two percent of the time, the battery life is 382 hours.

This battery life was well in excess of the expected amount. The original constraint was to use four AA batteries to produce a twenty-hour life. The 382-hour life is a calculated value based on constant operation with the LCD being on 2% of the time. The original time was set at twenty hours based on the battery life in a standard portable CD player. The standard portable CD player has an estimated battery life of ten hours at best. We wanted our device to last at least twice as long as the device it would most likely be used with. Users should be happy that the device will be able to operate well for extended periods. This design constraint was met much more easily than originally thought possible.

9.3 Size:

The size of the device was originally set to be 5" x 3" x 3". These measurements equate to 45 cu in. The FM Converter is a portable device. The primary benefit a user will get from it is that it can be carried anywhere and used with anything that has an audio output. Size plays a major role in how convenient a device is to use on the go. The most important part of this design requirement, the volume measurement, was met easily. However, the longest dimension constraint was not quite satisfied. The actual dimensions of the finished device are 7" x 3" x 1.5". The figure below illustrates these measurements.

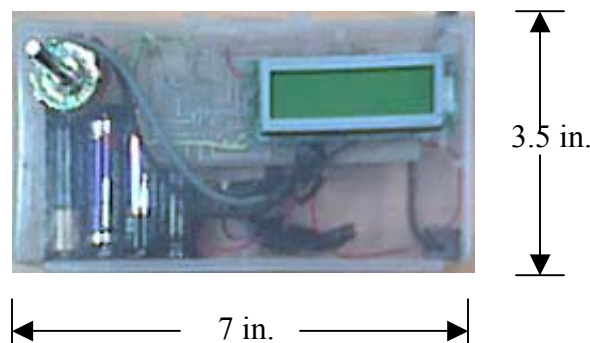

The depth of the device is 1.5". Despite the longest dimension constraint being exceeded, the device remains easily portable. Future improvements could certainly miniaturize the device further. Being under the volume limit means that this design requirement was satisfied.

9.4 Weight:

The target weight of the FM Converter was set at eight ounces. This limit was set to make the device similar in feel to that of a handheld cellular phone or similar portable equipment. The actual weight of the finished packaged unit was 6.8 oz. This was well within the requirement. During the design process, all components were carefully selected to ensure that this requirement could be met. The LCD was the biggest contributing factor but still did not cause concern. Keeping the unit lightweight adds to the convenience of transport and makes the FM Converter even more appealing. Future improvements could make the design even lighter. The weight design constraint was met.

9.5 Signal Clarity:

Signal Clarity is one aspect of the design requirements set during the first semester that did not see full completion. The original requirements for the device were to broadcast a FM stereo signal with quality as good as the best radio stations. Extensive research was done to determine the most effective way to produce a stereo encoded signal that would work with our device. The first few attempts for a working prototype involved using discrete components to complete most of the functions of encoding. None of the prototypes were completely successful. Several produced signals that were somewhat correct, but none were fully functional. Because of the significant, and unexpected, delays encountered with the stereo portion of this project, a modulator had to be selected that would work with either a stereo or mono signal. Such a modulator was designed. It is discussed in the modulator sub-section of the hardware section of this document. The stereo portion of the project was done in parallel with the design of other components. Using parallel design principles allowed work to proceed on other parts of the project without being hindered by the lack of progress with stereo.

Because of the noise and low-quality signals obtained from using discrete components to produce stereo, a stereo encoder was chosen to perform some of the functions. Producing a high-quality stereo signal is a complex task. Many of the components are sensitive to the electromagnetic fields produced by other components. By observing the problems being encountered with proximity and shielding on the breadboard, a decision was made to use a pre-packaged part. Using a chip eliminates many of the wires that introduce noise and distortion to the circuit. Chips were ordered and somewhat functional circuits were produced but completion of the primary unit took precedence over completion of the stereo portion.

Despite the lack of stereo capability, the device is still capable of performing the largest part of its intended use; providing reasonable quality sound with high versatility and low cost. The modulator used in the device can be used for stereo transmission. The modulator will modulate the type of signal it receives. If the stereo portion of the project were working properly, the modulator could modulate the encoded stereo signal. In its current state, the modulator receives a mono signal and modulates a mono signal. This is

an area for possible future development. Unfortunately, this design constrain was not met.

9.6 Operating Frequency:

The original requirement for operating frequency was for the unit to be tunable over the full range of FM radio frequencies. This was not produced in the packaged hardware. The packaged device is capable of tuning to three adjacent frequencies. The frequencies chosen were 88.1-88.5 MHz. This still provides the user with adequate range to find a free channel.

The full range tunability constraint required using a phase locked loop or PLL. This proved to be a large part of the difficulty with getting this section of the circuit working. The lack of full range tunability does not cause interference problems for the user. Full-range was not necessary for clear reception on the FM receiver. The requirement for full-range tunability was primarily a feature for user convenience. Once the first working prototypes were transmitting adequate signals from breadboard circuits, functional tests were conducted to prove adequate operation was possible. Even if a channel were occupied by a strong radio station, the FM Converter would “overpower” it if used in the intended proximity to the receiver. The reasoning behind the choice and spacing of frequencies is provided in the frequency choice section of this document.

Using three frequencies provides the user with enough range to operate interference free no matter where he or she travels. The tunability portion of this requirement was met. However, the full-range constraint was not satisfied.

9.7 Interface:

The interface requirement was to provide the user with a quick, easy to read way to see what channel was being transmitted and change frequencies with push-button tuning. This constraint was satisfied completely. The LCD chosen provides clear viewing from even small angles. The backlight feature even allows the user to see information at night. Backlighting is activated when the unit is powered on and when channels are changed. The light stays on five seconds and then goes off. Hardware explanations of the circuits and programs used for the interface portion of the project are seen in the interface section of this document. Additional information including programs and schematics is available on the FM Converter website: http://www.ece.msstate.edu/class/ece4522/public_html/projects/2001_fall/fm_converter/ All design constraints set for the display section of the project were satisfied.

The push-button section of the interface requirement was not met. Since the PLL was not used digital increments of the voltage controlled oscillator became more difficult. An analog tuner was used. The switch provided the user with three positions to transmit at. Three positions are adequate for interference-free operation. This section of the requirement was not met.

9.8 Audio Input:

The original requirement for audio inputs was to use mini plugs. Mini plugs were used in the finished packaged unit. RCA adaptors can be used to allow the user to operate devices with RCA output jacks with the FM Converter. This design requirement was met.

10. INPUT VS. OUTPUT

The finished packaged unit, as well as the breadboard versions, produced good sound quality when music was played. However, a graphical comparison of output to both simulation and audio input was needed to ensure that the device was functioning properly.

To produce such information, similar signals had to be compared. However, a simple input/output trace of the device is not only difficult to obtain, it is difficult to interpret. The input to the FM Converter is an audio signal ranging from less than one volt to over four volts. The frequency of the input is in the low kilohertz range. On the other hand, the frequency of the output is between 88.1 MHz and 88.5 MHz. The frequency difference alone does not present difficulties in obtaining input/output comparisons. One of the difficulties is that the output signal is a modulated FM version of the input signal. The inputs and outputs of each of the three converter components are all relatively easy to obtain and easy to interpret. However, when all three networks are connected, the input of the entire system is not easily comparable to the output. For a musical signal, the delays that occur with modulation make interpretation of data nearly impossible.

To avoid the problem of interpreting data generated by musical inputs, sinusoidal tones were generated using a laptop running the program "Cool Edit." This software allows the user to generate any tone they desire, even with different waveforms. The interpretation of modulated data amplified for transmission is still difficult. To attain a more

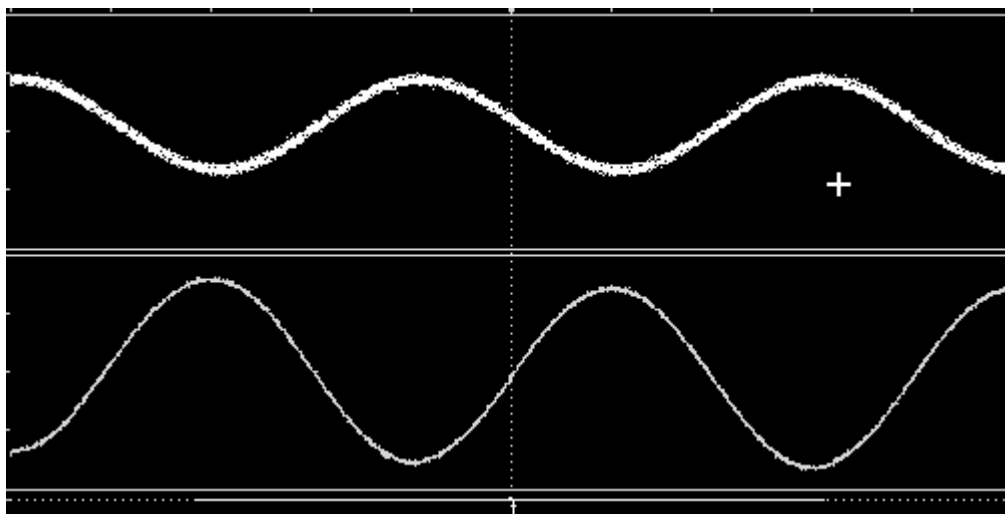

Figure 10-1. 5kHz Signal

meaningful waveform, the input to the FM Converter from the laptop was monitored on channel one of the oscilloscope. Channel two of the oscilloscope

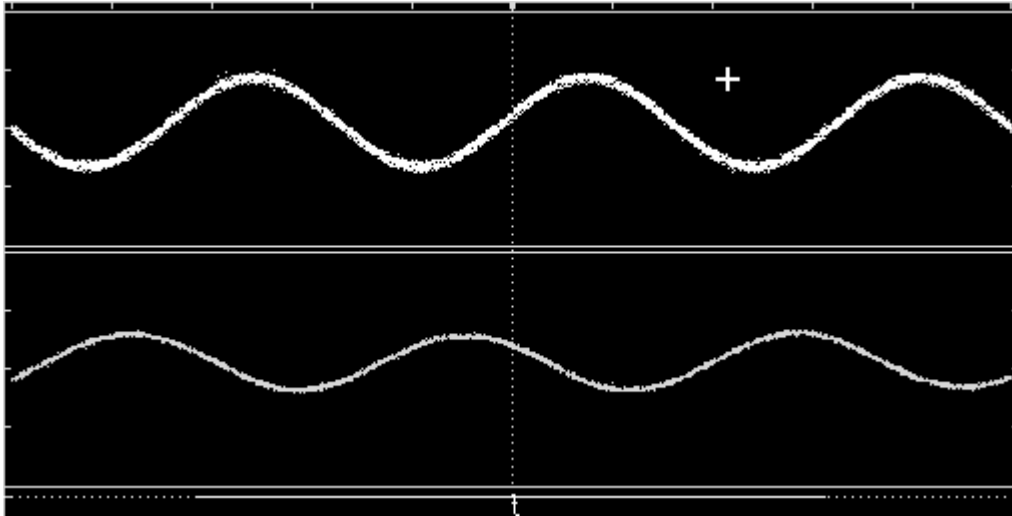

Figure 10-3. 15kHz Signal

pe was connected to the headphone jack of the FM radio. This provides a comparison of audio input to audio output.

Even this comparison has some irregularities that need to be accounted for. There are three delays that take place between when the signal reaches the input and when it reaches the output. First, the delay caused by the converter itself shifts the time of the waveform slightly. Second, the actual transmission of the signal causes a delay. This amount of time is negligible. The FM receiver causes the third delay. This occurs between when the transmitted signal reaches the radio and when it is output to the headphone jack. Both the modulation and demodulation delays are significant when comparing input to output. Using the radio also introduces another source of noise to the waveform. Irregularities appearing in the output trace may no be caused by the converter.

To ensure that the device responded satisfactorily to changes in frequency, several different frequencies were used. The human ear can hear from approximately 300 Hz to around 18 kHz. Waveforms for many frequencies in this range were obtained during hardware testing of the packaged unit. The representative frequencies of 5 kHz, 10 kHz, and 15 kHz are shown.

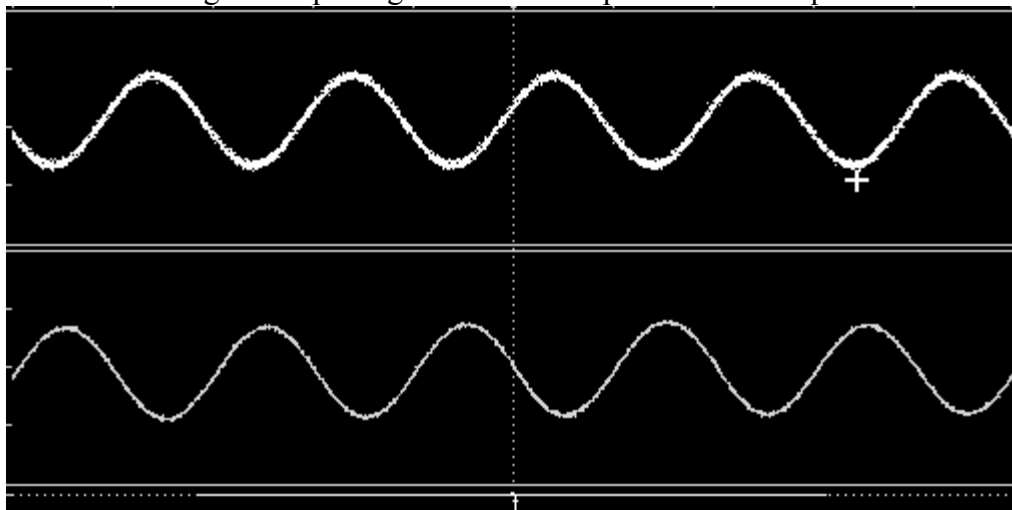

Figure 10-2. 10kHz Signal

and 15 kHz are shown.

By examining the plots, it is clear that the input and output waveforms are quite

similar. The amplitudes are somewhat different because of the volume levels of the input and output device. The first plot shows a 5 kHz sinusoidal tone input and output. The second and third plots show the input and outputs of the 10 kHz and 15 kHz respectively. Other than the time shifts discussed previously, the waves are essentially unchanged after traveling through both devices. These plots present a visual confirmation of the quality of the sound waves produced by the receiving unit. It is a means of representing audio clarity with visual tools.

The unit produces satisfactory output. Adding another device to the setup for testing incorporates another source of interference and noise. Producing acceptable signals under such conditions is even more difficult. These output waveforms verify the sound quality apparent to the human ear.

11. ACKNOWLEDGEMENTS

We would like to thank Dr. Georgios Lazarou of Mississippi State University for giving us his guidance, time and resources. We would also like to thank Dr. Picone, Dr. Winton and Dave Paul for their support and input.

12. REFERENCES

- [1] Tomasi, W, *Electronic Communications System Fundamentals Through Advanced*. Prentice Hall, Upper Saddle River, NJ, 2001.
- [2] Vaisnys, A., Chen, E. Y., *Digital Audio Applications to Short Wave Broadcasting*, IEEE Catalog Number: 97TH8280, 1997.
- [3] National Archives and Research Administration
www.access.gpo.gov/nara/cfr/waisidx_98/47cfr15_98.html, April 10, 1999.
- [4] Brad Brannon, *Wide-dynamic-range A/D converters pave the way for wideband digital-radio receivers*, http://www.ednmag.com/reg/1996/110796/23df_07.htm
EDN Magazine, 1996.
- [5] VHF Narrowband FM Data Transmitter and Receiver Modules,
<http://www.radiometrix.co.uk/products/tx1rx1.htm>, Radiometrix.
- [6] Communications, http://www3.ncsu.edu/ECE480/480_com.htm#snr-dyr, North Carolina State University College of Electrical and Computer Engineering.
- [7] Tom Wheeler, *Electronic Communications for Technicians*, Prentice Hall, Upper Saddle River, NJ, USA, 2001.
- [8] Automotive Vibration Testing, *The Institution of Electrical Engineers*; Savoy Place, London, 1999.

- [9] Walsh, P. *Vibration Design and Testing of Vehicle Electronic Systems*; The Institution of Electrical Engineers, 1995.
- [10] Nattrass, H. L., *Digital Measurement of FM Transmitter Quality*; The Institution of Electrical Engineers, 1995.
- [11] Hickman, I., *Analog Electronics Analog Circuitry Explained*. CRC Press, Inc, Boca Raton, FL 1990.
- [12] Lenk, J., *Handbook of Practical Electronic Circuits*. Prentis Hall, Englewood Cliffs, NJ 1982.
- [13] Lindsey, W., Simon, M, *Phase-Locked Loop & Their Application*. IEEE Press 1977.
- [14] Newby, B., *Electronic Signal Conditioning*. Butterworth/Heinmann Oxford 1994.
- [15] Blanchard, *Phase-Locked Loops*. John Wiley & Sons, New York 1976.
- [16] <http://www.ee.ed.ac.uk/~gjr/EE3/Comms>
- [17] <http://www.vetnetwork.com/season/heatstroke.html>