Computer Aided Digital Systems Design - EE 4743/6743

Sherif Abdelwahed

Pulse Width Modulation

**Department of Electrical and Compute Engineering
Mississippi State University**

Digital/Analog Conversion

- Digital 1/0 represented by high/low voltage
 - Can also define it as halfway voltage
 - 1 is above this halfway voltage
 - 0 is below
 - We can have more divisions in a voltage range
 - Each range is assigned a digital code
 - This is an Analog to Digital Conversion
 - Can take a digital representation and produce an Analog voltage
 - Usually a fixed value
 - So we lose resolution in the process
-

Digital/Analog Voltage Levels

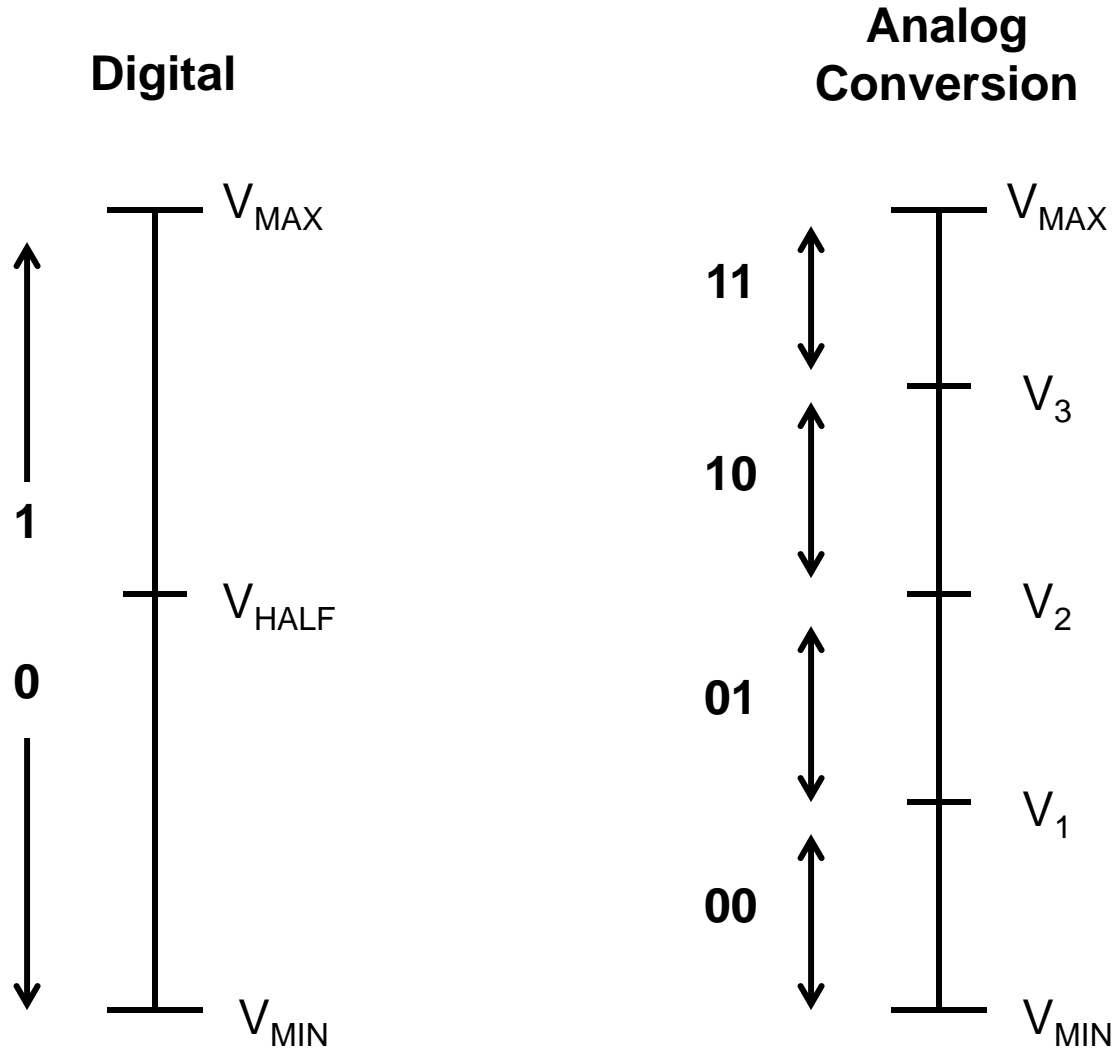

Pulse Width Modulation (PWM)

- Technique for using Digital circuit to control an Analog device
 - PWM is a way to encode an analog voltage using a digital signal
 - Start with a clock signal (repeating 1/0 values)
 - If we measure a clock signal with a DC multimeter
 - We read an average voltage
 - Somewhere between V_H and V_L
 - Duty cycle is varied to represent different voltage levels
 - Given sufficient resolution, any analog voltage can be represented in PWM
-

Principle

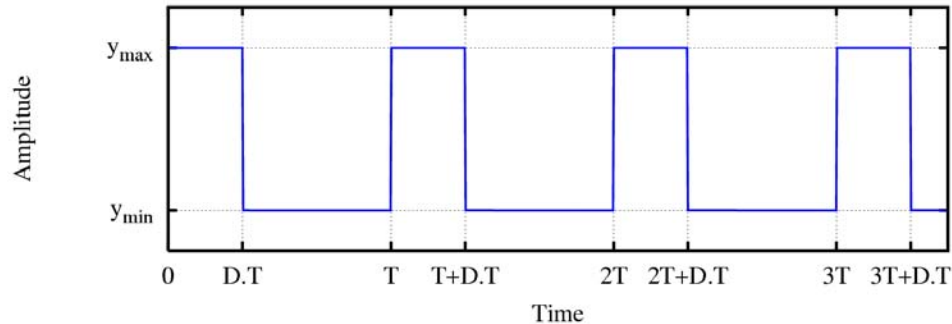

- **Pulse-width modulation** uses a square wave whose duty cycle is modulated resulting in the variation of the average value of the waveform.
- If we consider a square waveform $f(t)$ with a low value y_{min} , a high value y_{max} and a duty cycle D , the average value of the waveform is given by:

$$\begin{aligned}\bar{y} &= \frac{1}{T} \left(\int_0^{D.T} y_{max} dt + \int_{D.T}^T y_{min} dt \right) \\ &= \frac{D \cdot T \cdot y_{max} + T(1-D)y_{min}}{T} \\ &= D \cdot y_{max} + (1 - D) y_{min}\end{aligned}$$

PWM Signal

10%



50%

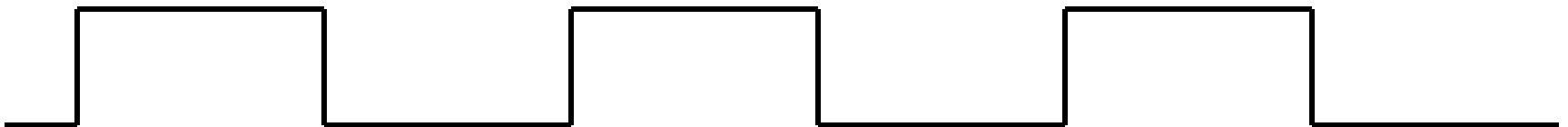

90%



Modulating Frequency

PWM Representation

- 10% signal is high for 10% of the cycle
 - If a 9V supply is used, then it represents 10% of that voltage, so 0.9V.
- 50% signal is high for half the cycle
 - If a 9V supply is used, then it represents 50% or 4.5V
- PWM signal can only represent a voltage as high as the input voltage

Analog Circuit Control

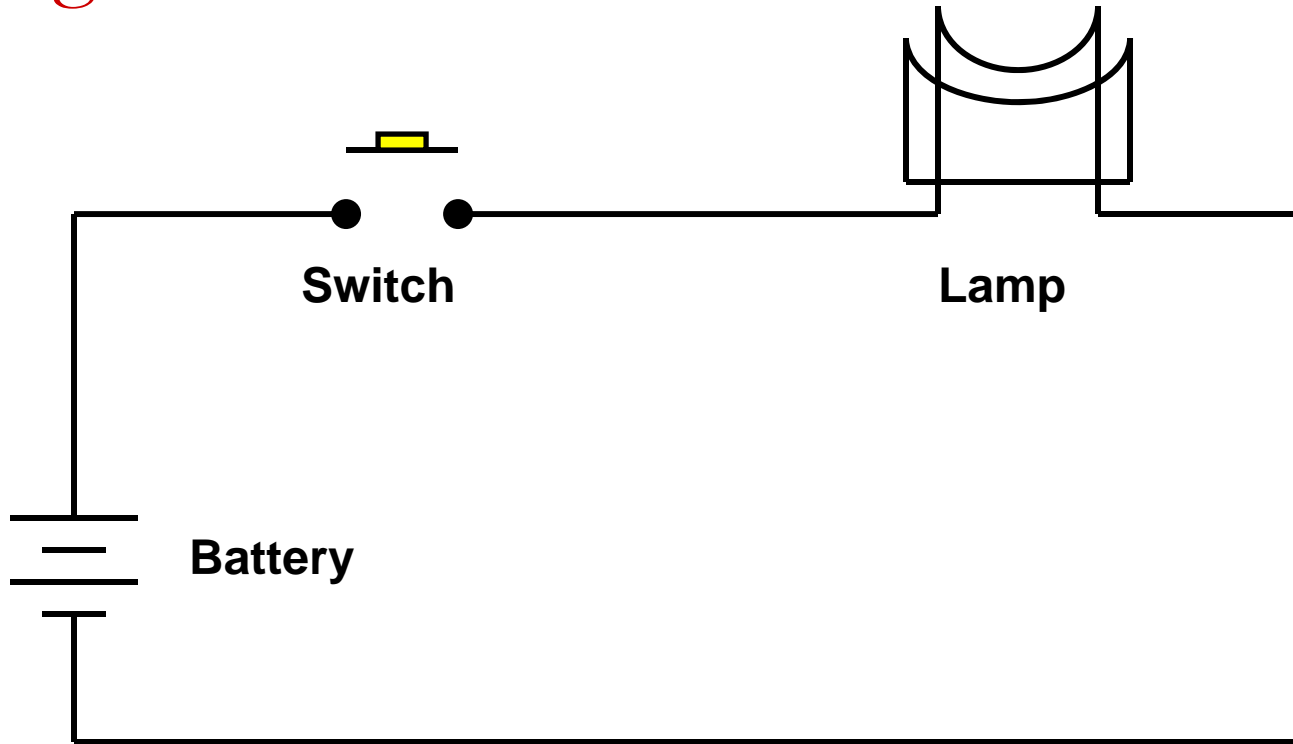

Modulation Frequency

- Modulating frequency depends on the response time of the analog circuit
 - If the switch was toggled every 5s at 50% duty cycle, the lamp might simply turn on and off
 - Faster frequencies are required to produce an average voltage
 - Dependant on capacitance and inductance
 - Typical frequencies: 1kHz-200kHz
-

PWM Advantages

- No Digital/Analog conversion of signal
 - Increase noise immunity
 - Good for communication
 - Increases effective communication channel
 - Receiving end can switch back to analog signal with simple RC or LC circuit
-

PWM Implementation

System Clock

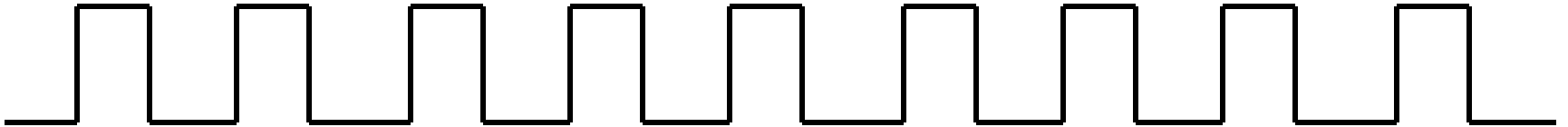

33% PWM

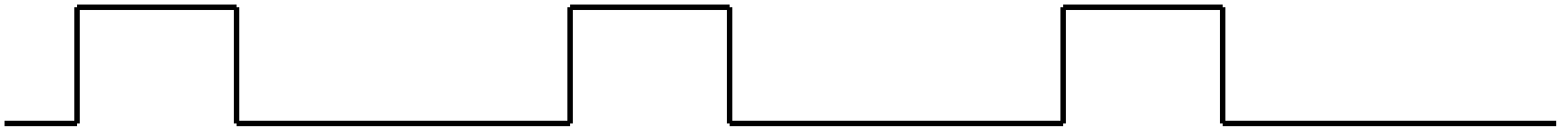

66% PWM



PWM Applications

■ **Communications**

- the widths of the pulses correspond to specific data values encoded at one end and decoded at the other.

■ **Power delivery**

- speed control of electric motors
- Home use light dimmers

■ **Voltage regulation**

- switching voltage to the load with the appropriate duty cycle, the output will approximate a voltage at the desired level.

■ **Audio effects and amplification**

- sound synthesis
 - class-D amplifiers
-