

## Electrostatic Boundary Value Problems

Many problems in electrostatics take the form of *boundary value problems* where the charge density or potential is known in certain regions or at certain boundaries. The governing partial differential equation defining potential in terms of its source (charge density) is *Poisson's equation*. The derivation of Poisson's equation begins with the differential form of Gauss's law.

$$\nabla \cdot \mathbf{D} = \rho_v$$

Inserting the relationship between electric field and electric flux density gives

$$\nabla \cdot (\epsilon \mathbf{E}) = \rho_v$$

Assuming a homogeneous medium, the permittivity may be treated like a constant and brought outside the divergence operator.

$$\epsilon (\nabla \cdot \mathbf{E}) = \rho_v$$

Substituting the electric field definition in terms of the gradient

$$\mathbf{E} = -\nabla V$$

yields

$$-\epsilon (\nabla \cdot \nabla V) = \rho_v$$

Dividing both sides of the equation by the permittivity yields Poisson's equation:

$$\nabla \cdot \nabla V = -\frac{\rho_v}{\epsilon}$$

The divergence of the gradient of a scalar is defined as the *Laplacian operator* and designated by  $\nabla^2$  in operator notation.

$$\nabla \cdot \nabla V \equiv \nabla^2 V$$

Using the definition of the Laplacian operator, Poisson's equation can be written as

$$\nabla^2 V = -\frac{\rho_v}{\epsilon} \quad (\text{Poisson's equation})$$

A special case of Poisson's equation is *Laplace's equation* in which the source term (charge density) is zero.

$$\nabla^2 V = 0 \quad (\text{Laplace's equation})$$

Thus, Poisson's equation governs the potential behavior in regions where free charge exists, while Laplace's equation governs the potential behavior in regions where no free charge exists.

### Uniqueness

A unique solution to a given boundary value problem in a specific region is ensured if

- (1.) We use the proper governing D.E. (there are an infinite number of solutions to the D.E.).
- (2.) We use the proper boundary conditions (there are an infinite number of solutions to the boundary conditions).

There is only one (unique) solution to the governing differential equation that also satisfies the given boundary conditions. By defining the proper physics in the problem (proper boundary conditions), we ensure a unique solution to the governing differential equation.

## Laplace / Poisson Equation Solutions

The techniques used to solve Laplace's and Poisson's equation are dependent on the dimensional complexity of the problem. For one-dimensional (1-D) problems [potential is a function of one variable only], where the governing partial differential equation (PDE) reduces to an ordinary differential equation (ODE), we can simply integrate once to determine the electric field and twice to determine the potential. For 2-D and 3-D problems, procedures such as the separation of variables technique are necessary.

Example (1-D solution / Poisson's equation / semiconductor junction)

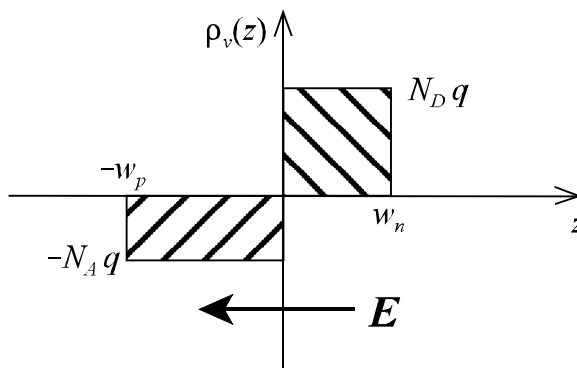
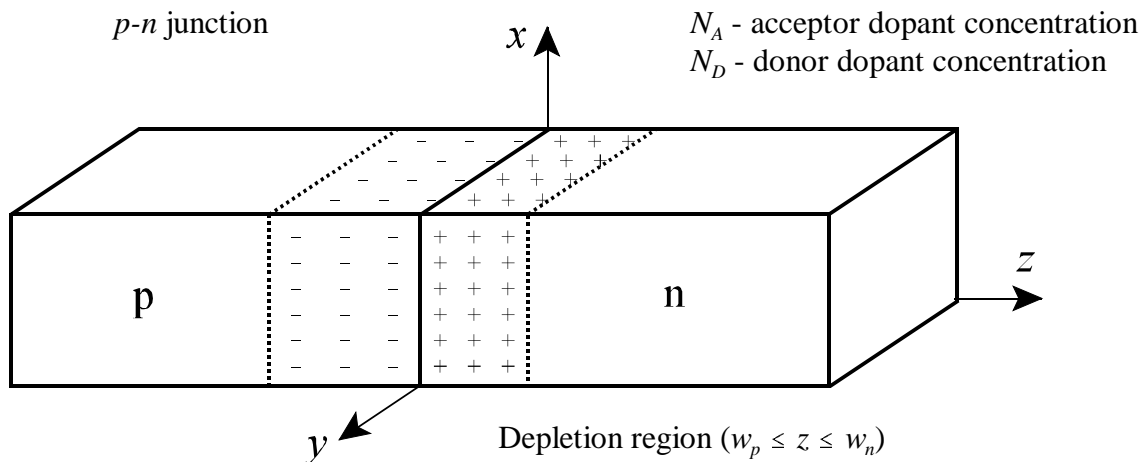

$\left. \begin{array}{l} n\text{-type silicon} \\ p\text{-type silicon} \end{array} \right\}$  Homogeneous medium (silicon permittivity  $\epsilon = 11.8\epsilon_0$ )

We assume no variation in the p-n junction potential and electric field in the  $x$  or  $y$  directions (1D problem)  $\Rightarrow V(z), E_z(z)$

Poisson's equation is the governing differential equation that relates the charge density in the p-n junction depletion region to the potential distribution in the p-n junction.

$$\nabla^2 V = \frac{\partial^2 V}{\partial x^2} + \frac{\partial^2 V}{\partial y^2} + \frac{\partial^2 V}{\partial z^2} = -\frac{\rho_v}{\epsilon}$$

Assuming a 1D solution (no variation in the  $x$  or  $y$  directions), Poisson's equation reduces to

$$\frac{d^2 V(z)}{dz^2} = -\frac{\rho_v}{\epsilon}$$

or

$$\frac{d^2 V(z)}{dz^2} = -\frac{N_D q}{\epsilon} \quad (0 \leq z \leq w_n)$$

$$\frac{d^2 V(z)}{dz^2} = \frac{N_A q}{\epsilon} \quad (-w_p \leq z \leq 0)$$

The regions away from the depletion region are charge neutral ( $E = \mathbf{0}$  and  $V = \text{constant}$ ). Thus, the p-n junction boundary conditions are

$$E_z(-w_p) = 0 \quad E_z(w_n) = 0$$

$$V(0) = 0 \quad (\text{reference point at } z=0)$$

The electric field within the p-n junction is found by integrating Poisson's equation with respect to  $z$ .

$$\int \frac{d^2 V(z)}{dz^2} dz = -\frac{N_D q}{\epsilon} \int dz \quad (0 \leq z \leq w_n)$$

$$\int \frac{d^2 V(z)}{dz^2} dz = \frac{N_A q}{\epsilon} \int dz \quad (-w_p \leq z \leq 0)$$

$$\frac{dV(z)}{dz} = -\frac{N_D q}{\epsilon} z + C_1 \quad (0 \leq z \leq w_n)$$

$$\frac{dV(z)}{dz} = \frac{N_A q}{\epsilon} z + C_2 \quad (-w_p \leq z \leq 0)$$

where  $C_1$  and  $C_2$  are constants of integration. The first derivative of  $V(z)$  with respect to  $z$  is equal to  $-E_z(z)$  according to

$$\begin{aligned} \mathbf{E}(z) &= -\nabla V(z) \\ &= -\left[ \frac{\partial V(z)}{\partial x} \mathbf{a}_x + \frac{\partial V(z)}{\partial y} \mathbf{a}_y + \frac{\partial V(z)}{\partial z} \mathbf{a}_z \right] \\ &= -\frac{dV(z)}{dz} \mathbf{a}_z = E_z(z) \mathbf{a}_z \quad \Rightarrow \quad E_z(z) = -\frac{dV(z)}{dz} \end{aligned}$$

The integral of Poisson's equation may then be written as

$$-E_z(z) = -\frac{N_D q}{\epsilon} z + C_1 \quad \Rightarrow \quad E_z(z) = \frac{N_D q}{\epsilon} z - C_1 \quad (0 \leq z \leq w_n)$$

$$-E_z(z) = \frac{N_A q}{\epsilon} z + C_2 \quad \Rightarrow \quad E_z(z) = -\frac{N_A q}{\epsilon} z - C_2 \quad (-w_p \leq z \leq 0)$$

Application of the electric field boundary conditions at the edges of the depletion region determines the unknown constants.

$$E_z(w_n) = 0 = \frac{N_D q}{\epsilon} w_n - C_1 \quad \Rightarrow \quad C_1 = \frac{N_D q}{\epsilon} w_n$$

$$E_z(-w_p) = 0 = -\frac{N_A q}{\epsilon} w_p - C_2 \quad \Rightarrow \quad C_2 = -\frac{N_A q}{\epsilon} w_p$$

$$E_z(z) = \frac{N_D q}{\epsilon} (z - w_n) \quad (0 \leq z \leq w_n)$$

$$E_z(z) = -\frac{N_A q}{\epsilon} (z + w_p) \quad (-w_p \leq z \leq 0)$$

To determine the potential within the p-n junction, we integrate a second time with respect to  $z$ .

$$E_z(z) = -\frac{dV(z)}{dz} = \frac{N_D q}{\epsilon} (z - w_n) \quad (0 \leq z \leq w_n)$$

$$E_z(z) = -\frac{dV(z)}{dz} = -\frac{N_A q}{\epsilon} (z + w_p) \quad (-w_p \leq z \leq 0)$$

$$\int \frac{dV(z)}{dz} dz = -\frac{N_D q}{\epsilon} \int (z - w_n) dz \quad (0 \leq z \leq w_n)$$

$$\int \frac{dV(z)}{dz} dz = \frac{N_A q}{\epsilon} \int (z + w_p) dz \quad (-w_p \leq z \leq 0)$$

$$V(z) = -\frac{N_D q}{\epsilon} \left( \frac{z^2}{2} - w_n z \right) + C_3 \quad (0 \leq z \leq w_n)$$

$$V(z) = \frac{N_A q}{\epsilon} \left( \frac{z^2}{2} + w_p z \right) + C_4 \quad (-w_p \leq z \leq 0)$$

Application of the potential boundary condition [ $V(0)=0$ ] gives

$$C_3 = 0 \Rightarrow V(z) = -\frac{N_D q}{\epsilon} \left( \frac{z^2}{2} - w_n z \right) \quad (0 \leq z \leq w_n)$$

$$C_4 = 0 \Rightarrow V(z) = \frac{N_A q}{\epsilon} \left( \frac{z^2}{2} + w_p z \right) \quad (-w_p \leq z \leq 0)$$

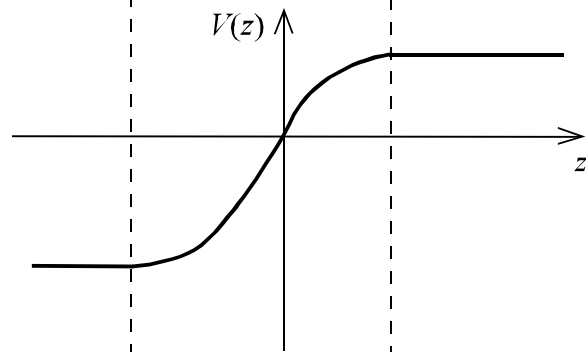
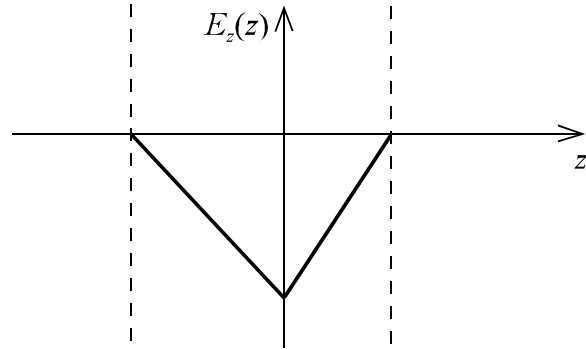
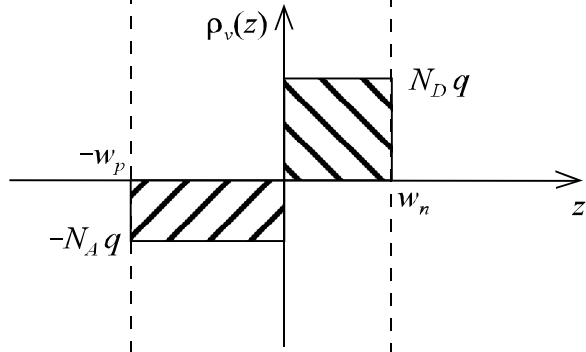
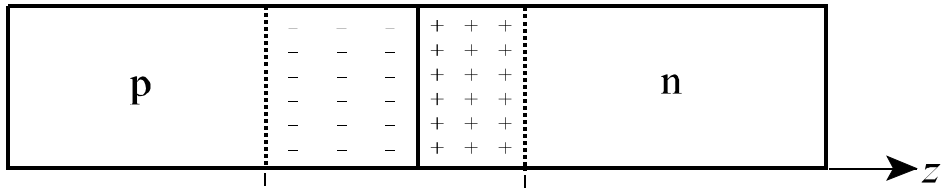

## Separation of Variables

The direct integration technique used in 1-D problems (ODE's) is not applicable to 2-D and 3-D problems (PDE's). The *separation of variables* technique is applicable to certain *separable* coordinate systems including rectangular, cylindrical and spherical coordinates.

Example (Separation of variables technique)

The 3-D potential in a charge-free region in rectangular coordinates is characterized by Laplace's equation:

$$\nabla^2 V = \frac{\partial^2 V}{\partial x^2} + \frac{\partial^2 V}{\partial y^2} + \frac{\partial^2 V}{\partial z^2} = 0$$

Note that Laplace's equation is a 3-D, 2<sup>nd</sup> order PDE. The separation of variables technique is based on the assumption that the solution to the PDE may be written as the product of functions of only one variable. Thus, the 3-D solution for the potential is assumed to be

$$V(x,y,z) = X(x)Y(y)Z(z)$$

Inserting the assumed solution into Laplace's equation yields

$$Y(y)Z(z) \frac{d^2 X(x)}{dx^2} + X(x)Z(z) \frac{d^2 Y(y)}{dy^2} + X(x)Y(y) \frac{d^2 Z(z)}{dz^2} = 0$$

Dividing this equation by the assumed solution gives

$$\frac{1}{X(x)} \frac{d^2 X(x)}{dx^2} + \frac{1}{Y(y)} \frac{d^2 Y(y)}{dy^2} + \frac{1}{Z(z)} \frac{d^2 Z(z)}{dz^2} = 0$$

The three terms on the left hand side of the equation above are each dependent on only one variable. Thus, we may write

$$f_1(x) + f_2(y) + f_3(z) = 0$$

The individual functions must add to zero for all values of  $x$ ,  $y$ , and  $z$  in the 3-D region of interest. Thus, each of these three functions must be constants, such that

$$\frac{1}{X(x)} \frac{d^2 X(x)}{dx^2} = \lambda_1^2 \quad \Rightarrow \quad \frac{d^2 X(x)}{dx^2} - \lambda_1^2 X(x) = 0$$

$$\frac{1}{Y(y)} \frac{d^2 Y(y)}{dy^2} = \lambda_2^2 \quad \Rightarrow \quad \frac{d^2 Y(y)}{dy^2} - \lambda_2^2 Y(y) = 0$$

$$\frac{1}{Z(z)} \frac{d^2 Z(z)}{dz^2} = \lambda_3^2 \quad \Rightarrow \quad \frac{d^2 Z(z)}{dz^2} - \lambda_3^2 Z(z) = 0$$

and

$$\lambda_1^2 + \lambda_2^2 + \lambda_3^2 = 0 \quad (\text{separation equation})$$

Note that the original 3-D 2<sup>nd</sup> order PDE has been transformed into three 1-D 2<sup>nd</sup> order ODE's subject to the *separation equation*. The general solutions to the three separate ODE's are of the following form:

$$\begin{aligned} X(x) &= \{ \sin \lambda_1 x, \cos \lambda_1 x, \sinh \lambda_1 x, \cosh \lambda_1 x \} \\ Y(y) &= \{ \sin \lambda_2 y, \cos \lambda_2 y, \sinh \lambda_2 y, \cosh \lambda_2 y \} \\ Z(z) &= \{ \sin \lambda_3 z, \cos \lambda_3 z, \sinh \lambda_3 z, \cosh \lambda_3 z \} \end{aligned} \quad \begin{array}{l} \text{or linear} \\ \text{combinations} \\ \text{of these} \end{array}$$

Once each of the three individual functions is determined according to the boundary conditions of the problem, the overall solution is simply the product of these three functions.

## Capacitors and Capacitance

A *capacitor* is an energy storage device that stores energy in an electric field. A capacitor consists of two conductors separated by an insulating medium. If the capacitor conductors are assumed to be initially uncharged (neutral), the application of a voltage (potential difference) between the conductors causes a charge separation ( $+Q$  on one conductor and  $-Q$  on the opposite conductor). This charge separation produces an electric field within the insulating medium between the conductors (permittivity =  $\epsilon$ ) such that energy is stored in the capacitor.

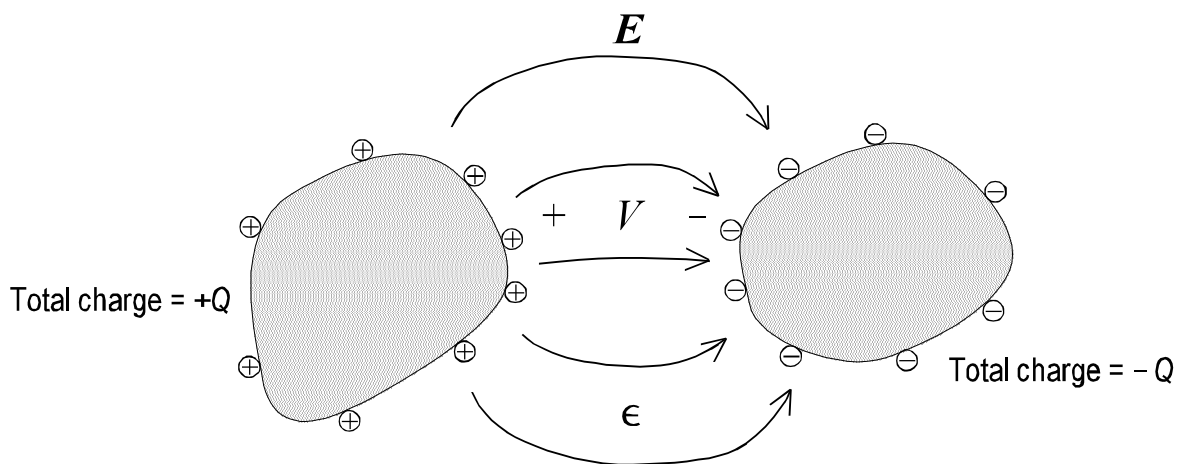

The magnitude of the charge stored on either conductor is proportional to the voltage applied between the conductors. The ratio of the total charge magnitude on either conductor to the potential difference between the conductors defines the *capacitance*.

$$C \equiv \frac{Q}{V} \quad (\text{capacitance})$$

The capacitance of a capacitor depends only on the geometry of the conductors (conductor shape, separation distance, etc.) and the permittivity of the insulating medium between the capacitor conductors. According to the definition of capacitance, the charge on a capacitor conductor increases at the same rate as the capacitor voltage (e.g., if the capacitor voltage is doubled, the charge on each conductor is doubled).

### Example (Capacitor)

Determine  $\mathbf{E}$  and  $V$  between two perfectly conducting plates of infinite extent in a homogeneous dielectric ( $\sigma=0, \epsilon=\epsilon_r\epsilon_o$ ). The plates are separated by a distance  $d$  with a potential difference of  $V_o$  between the plates.

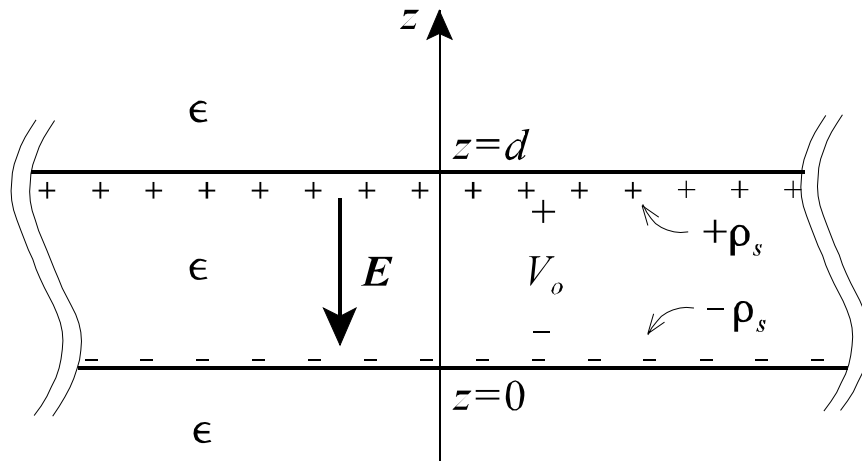

Due to symmetry, the charge distribution on the plates must be uniform. The electric field can be determined by superposition using the electric field expression for a uniformly charged plate of infinite extent.

$$\mathbf{E} = \mathbf{E}(+\rho_s) + \mathbf{E}(-\rho_s)$$

Between the plates ( $0 \leq z \leq d$ ),

$$\begin{aligned}\mathbf{E} &= \mathbf{E}(+\rho_s) + \mathbf{E}(-\rho_s) \\ &= \frac{\rho_s}{2\epsilon}(-\mathbf{a}_z) + \frac{-\rho_s}{2\epsilon}(+\mathbf{a}_z) \\ &= -\frac{\rho_s}{\epsilon}\mathbf{a}_z = -E_o\mathbf{a}_z \quad (\text{uniform})\end{aligned}$$

Above the plates ( $z > d$ ),

$$\begin{aligned}\mathbf{E} &= \mathbf{E}(+\rho_s) + \mathbf{E}(-\rho_s) \\ &= \frac{\rho_s}{2\epsilon} (+\mathbf{a}_z) + \frac{-\rho_s}{2\epsilon} (+\mathbf{a}_z) = 0\end{aligned}$$

Below the plates ( $z < d$ ),

$$\begin{aligned}\mathbf{E} &= \mathbf{E}(+\rho_s) + \mathbf{E}(-\rho_s) \\ &= \frac{\rho_s}{2\epsilon} (-\mathbf{a}_z) + \frac{-\rho_s}{2\epsilon} (-\mathbf{a}_z) = 0\end{aligned}$$

Thus, the electric field is uniform between the plates and zero elsewhere. The potential between the plates varies linearly given a uniform electric field according to the definition of the electric field as the gradient of the potential. The potential between the plates is a function of  $z$  only (1-D problem) such that

$$\mathbf{E} = -\nabla V = -\frac{dV}{dz} \mathbf{a}_z = -\frac{\rho_s}{\epsilon} \mathbf{a}_z = -E_o \mathbf{a}_z$$

$$\frac{dV}{dz} = \frac{\rho_s}{\epsilon} = E_o$$

Integrating this equation gives

$$\int \frac{dV}{dz} dz = \int E_o dz$$

$$V(z) = E_o z + C$$

Assuming that the bottom plate is used as a voltage reference (ground), then the absolute potentials on the capacitor plates are

$$V(0) = 0 = E_o(0) + C \quad \Rightarrow \quad C = 0$$

$$V(d) = V_o = E_o(d) + C \quad \Rightarrow \quad V_o = E_o d$$

such that the potential between the plates is given by

$$V(z) = E_o z$$

and the electric field between the plates is

$$\mathbf{E} = -\frac{V}{d} \mathbf{a}_z = -E_o \mathbf{a}_z$$

Note that the magnitude of the electric field between the plates is simply the ratio of the voltage between the plates to the plate separation distance.

This capacitor problem can also be solved as a boundary value problem. The governing differential equation is Laplace's equation given the ideal dielectric between the plates of the capacitor ( $\rho_v=0$ ).

$$\nabla^2 V = \frac{\partial^2 V}{\partial x^2} + \frac{\partial^2 V}{\partial y^2} + \frac{\partial^2 V}{\partial z^2} = 0$$

With no variation in the potential in the  $x$  or  $y$  directions (by symmetry), Laplace's equation in rectangular coordinates reduces to the following 1-D form:

$$\frac{d^2 V}{dz^2} = 0$$

The boundary conditions on the potential are

$$V(0) = 0 \quad V(d) = V_o$$

Integrating both sides of Laplace's equation with respect to  $z$  gives

$$\int \frac{d^2 V}{dz^2} dz = \int (0) dz$$

$$\frac{dV}{dz} = C_1$$

Integrating again gives

$$\int \frac{dV}{dz} dz = \int C_1 dz$$

$$V(z) = C_1 z + C_2$$

Application of the capacitor boundary conditions yields

$$V(0) = 0 = C_1(0) + C_2 \quad \Rightarrow \quad C_2 = 0$$

$$V(d) = V_o = C_1(d) + C_2 \quad \Rightarrow \quad C_1 = \frac{V_o}{d}$$

The potential between the plates is then

$$V(z) = \frac{V_o}{d} z$$

which is the same result found before. Note that the result of the first integration was the electric field between the plates.

$$\frac{dV}{dz} = C_1 = \frac{V_o}{d} = -E_z(z)$$

## Ideal Parallel Plate Capacitor

A commonly encountered capacitor geometry is the *parallel plate capacitor*. The parallel plate capacitor is formed by two large flat conducting plates of area  $A$  separated by a small distance  $d$ . The volume between the plates is filled with a homogeneous insulating medium of permittivity  $\epsilon$ .

### Parallel plate capacitor

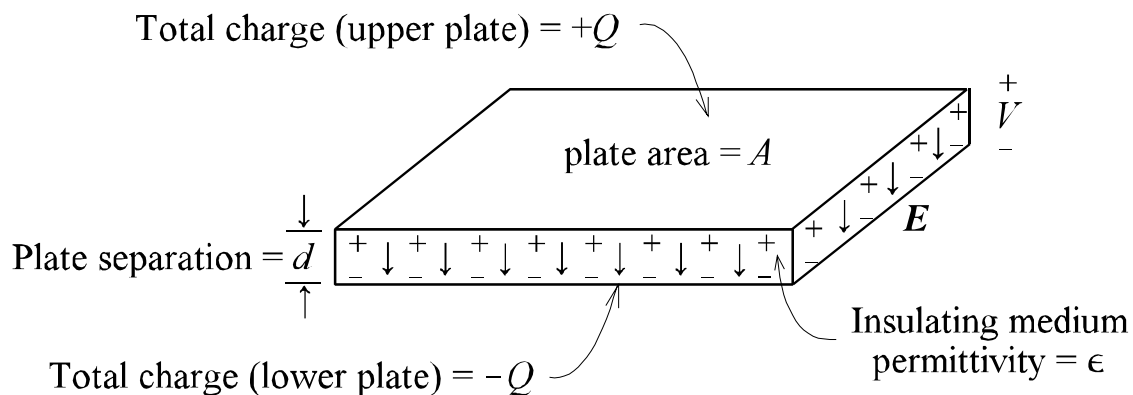

The charge and electric field characteristics in an actual parallel plate capacitor can be approximated using the *ideal parallel plate capacitor* model.

Assumptions for the ideal parallel plate capacitor model:

- (1) The plate surface charge densities are uniform ( $\rho_s = \pm Q/A$ ).
- (2) The electric field between the plates is uniform ( $E = V/d$ ).
- (3) The electric field outside the volume between the plates is zero.

In an actual parallel plate capacitor, the surface charge densities are not uniform since the charge density grows large at the edges of the plates. This crowding of charge at the conductor edges causes an effect known as *electric field fringing* (nonuniform electric field).

### Ideal Parallel Plate Capacitor

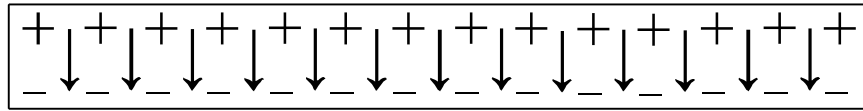

### Parallel Plate Capacitor

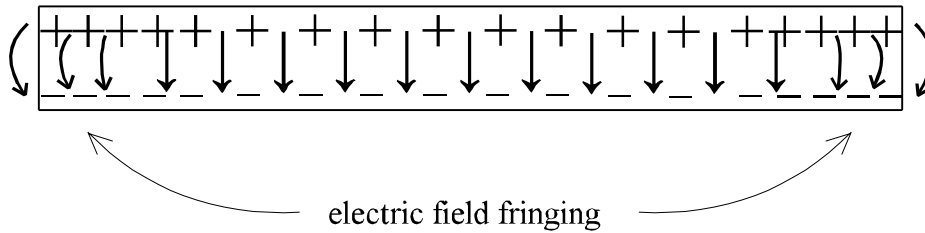

The amount of fringing in the electric field near the edges of the capacitor plates is small for closely-spaced large plates so that the ideal parallel plate capacitor model is accurate for most capacitors. The ideal parallel plate capacitor model becomes more accurate as the capacitor plate area grows larger and the capacitor plate separation grows smaller.

The equation for the capacitance of the ideal parallel plate capacitor is determined by starting with the capacitance definition in terms of charge and potential.

$$C = \frac{Q}{V}$$

The uniform electric field in the ideal parallel plate capacitor means that the electric flux density within the capacitor is also uniform.

$$\mathbf{D} = \epsilon \mathbf{E}$$

According to the electric flux boundary condition on the surface of either plate, the electric flux density component normal to the plate surface is equal to the uniform charge density on the plate.

$$D = \epsilon E = \rho_s = \frac{Q}{A} \quad \Rightarrow \quad Q = \epsilon EA$$

The uniform electric field within the capacitor may be written in terms of the potential  $V$  using

$$E = \frac{V}{d} \quad \Rightarrow \quad V = Ed$$

Inserting the equations for  $Q$  and  $V$  into the capacitance equation yields

$$C = \frac{Q}{V} = \frac{\epsilon EA}{Ed} = \frac{\epsilon A}{d} \quad \left( \begin{array}{l} \text{capacitance of an ideal} \\ \text{parallel plate capacitor} \end{array} \right)$$

Note that the capacitance of the ideal parallel plate capacitor is directly proportional to the plate area and the insulator permittivity and inversely proportional to the plate separation distance.

The total energy stored in the capacitor may be found by integrating the energy density associated with the capacitor electric field.

$$W_E = \iiint_V w_E dv \quad w_E = \frac{1}{2} \epsilon E^2$$

Given the uniform electric field in the volume between the plates of the ideal parallel plate capacitor, the energy density is also uniform, such that

$$W_E = w_E \iiint_V dv = w_E V = \left( \frac{1}{2} \epsilon E^2 \right) (Ad)$$

The total energy results above can be rearranged into the normal circuits equation for the total energy of a capacitor.

$$W_E = \left( \frac{1}{2} \epsilon E^2 \right) (Ad) = \frac{1}{2} (\epsilon EA)(Ed) = \frac{1}{2} QV \quad \underset{V = \frac{Q}{C}}{=} \quad \frac{1}{2} \frac{Q^2}{C} \quad \underset{Q = CV}{=} \quad \frac{1}{2} CV^2$$

The last three equations on the right hand side of the total energy equation above are valid for any capacitor.

## Coaxial Capacitor

A coaxial capacitor is formed by two concentric conducting cylinders (inner radius =  $a$ , outer radius =  $b$ , length =  $L$ ) separated by an insulating medium ( $\epsilon$ ). Uniform charge distributions on both capacitor conductors are assumed for the idealized model of a coaxial capacitor (just like the ideal parallel plate capacitor). In an actual coaxial capacitor, the charge densities grow large close to the ends of the conductors (sharp edges) where electric field fringing is seen. The ideal coaxial capacitor model is accurate for an actual coaxial capacitor which is long and has a small cross-sectional area (fringing is negligible).

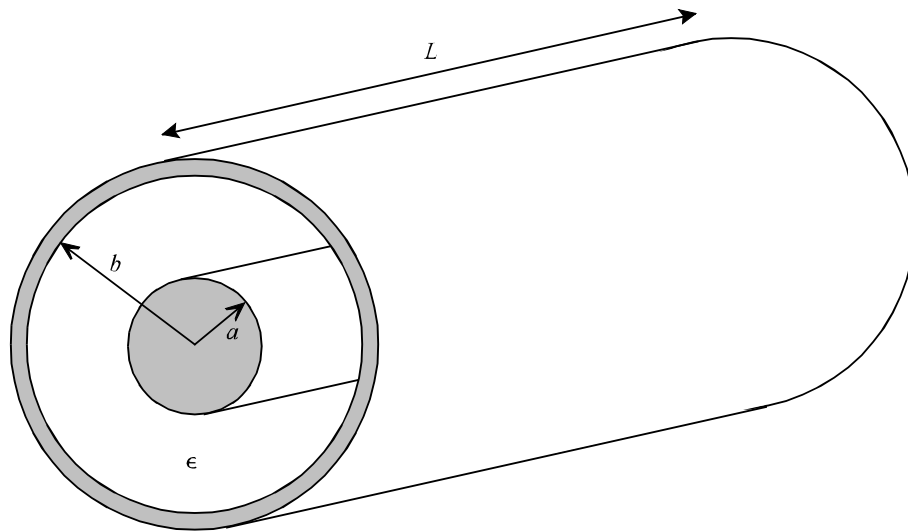

Assuming a voltage  $V$  is applied to the initially uncharged conductors of the coaxial capacitor (from the inner conductor to the outer conductor, using the outer conductor as the voltage reference), a total charge of  $+Q$  is produced on the surface of the inner cylinder and a total charge of  $-Q$  is produced on the inside surface of the outer cylinder. The uniform surface charge densities on the inner and outer capacitor conductors ( $\rho_{sa}$  and  $\rho_{sb}$ , respectively) are

$$\rho_{sa} = \frac{+Q}{A_a} = \frac{Q}{2\pi aL} \quad (\text{inner conductor})$$

$$\rho_{sb} = \frac{-Q}{A_b} = -\frac{Q}{2\pi bL} \quad (\text{outer conductor})$$

Note that the surface charge density on the inner conductor is larger than that on the outer conductor. This produces a nonuniform electric field ( $E_\rho$ ) within the coaxial capacitor. By symmetry,  $E_\rho$  is a function of  $\rho$  only.

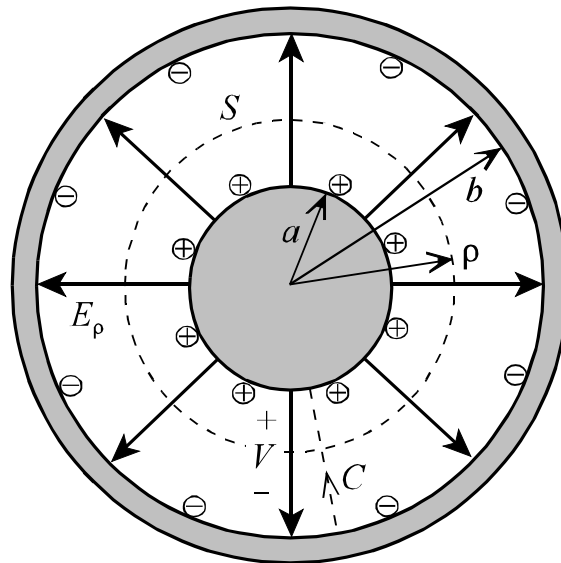

To determine the capacitance of the coaxial capacitor, we

- (1) determine the electric field  $E$  in terms of the charge  $Q$  using Gauss's law,
- (2) find the potential  $V$  in terms of  $Q$  by evaluating the line integral of the electric field, and
- (3) determine the capacitance using the capacitance definition. ( $C=Q/V$ ).

Applying Gauss's law on a closed cylindrical surface  $S$  of radius  $\rho$  such that ( $a \leq \rho \leq b$ ) yields

$$\oiint_S \mathbf{D} \cdot d\mathbf{s} = Q_{\text{enclosed}}$$

The closed surface includes the endcaps on either end of the cylindrical surface, but there is no electric flux component normal to the endcaps so that Gauss's law gives

$$\int_0^L \int_0^{2\pi} \epsilon E_\rho \rho d\phi dz = Q$$

$$\epsilon E_{\rho} \rho (2\pi)(L) = Q$$

$$E_{\rho} = \frac{Q}{2\pi\epsilon\rho L} \quad \Rightarrow \quad \mathbf{E}_{\rho} = \frac{Q}{2\pi\epsilon\rho L} \mathbf{a}_{\rho}$$

The voltage  $V$  across the capacitor conductors is found by evaluating the line integral of the electric field along the contour  $C$  from the outer conductor to the inner conductor.

$$\begin{aligned} V &= -\int_C \mathbf{E} \cdot d\mathbf{l} = -\int_b^a \left( \frac{Q}{2\pi\epsilon\rho L} \mathbf{a}_{\rho} \right) \cdot (-d\rho)(-\mathbf{a}_{\rho}) \\ &= -\frac{Q}{2\pi\epsilon L} \int_b^a \frac{d\rho}{\rho} = -\frac{Q}{2\pi\epsilon L} [\ln \rho]_b^a \\ &= -\frac{Q}{2\pi\epsilon L} [\ln a - \ln b] = -\frac{Q}{2\pi\epsilon L} \ln\left(\frac{a}{b}\right) \\ &= \frac{Q}{2\pi\epsilon L} \ln\left(\frac{b}{a}\right) \end{aligned}$$

The ratio of charge to potential for the capacitor gives the capacitance:

$$C = \frac{Q}{V} = \frac{2\pi\epsilon L}{\ln(b/a)} \quad \left( \begin{array}{l} \text{capacitance of an} \\ \text{ideal coaxial capacitor} \end{array} \right)$$

A convenient parameter is the *per-unit-length* capacitance for the coaxial capacitor. The per-unit-length capacitance is found by dividing the capacitance  $C$  by the capacitor length. This yields

$$C' = \frac{C}{L} = \frac{2\pi\epsilon}{\ln(b/a)} \quad \left( \begin{array}{l} \text{per-unit-length capacitance of} \\ \text{an ideal coaxial capacitor} \end{array} \right)$$

The units on per-unit-length capacitance are F/m. The overall capacitance of a particular length coaxial capacitor is found by multiplying the per-unit-length capacitance by the length  $L$ .

## Spherical Capacitor

A capacitor can also be formed using two concentric spherical conductors (inner radius =  $a$ , outer radius =  $b$ ) separated by an insulating medium ( $\epsilon$ ). The ideal spherical capacitor is characterized by uniform charge densities on the surfaces of both the inner and outer conductors.

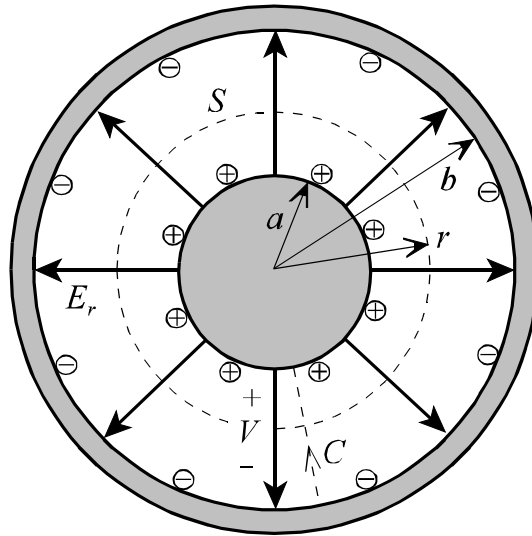

The uniform surface charge densities on the inner and outer conductors of the ideal spherical capacitor ( $\rho_{sa}$  and  $\rho_{sb}$ , respectively) are

$$\rho_{sa} = \frac{+Q}{A_a} = \frac{Q}{4\pi a^2} \quad (\text{inner conductor})$$

$$\rho_{sb} = \frac{-Q}{A_b} = -\frac{Q}{4\pi b^2} \quad (\text{outer conductor})$$

The surface charge density on the inner conductor is larger than that on the outer conductor given the larger surface area of the outer conductor. This produces a nonuniform electric field ( $E_r$ ) within the spherical capacitor which is a function of  $r$  only, by symmetry. The process used to determine the capacitance of the ideal spherical capacitor is the same as that used for the ideal cylindrical capacitor.

Applying Gauss's law on a closed spherical surface  $S$  of radius  $r$  such that  $(a \leq r \leq b)$  yields

$$\oiint_S \mathbf{D} \cdot d\mathbf{s} = Q_{\text{enclosed}}$$

Inserting the spherical capacitor electric flux density ( $\mathbf{D} = \epsilon E_r \mathbf{a}_r$ ) gives

$$\int_0^{2\pi} \int_0^{\pi} \epsilon E_r r^2 \sin \theta d\theta d\phi = Q$$

$$\epsilon E_r r^2 (2\pi)(2) = Q$$

$$E_r = \frac{Q}{4\pi\epsilon r^2} \quad \Rightarrow \quad \mathbf{E}_r = \frac{Q}{4\pi\epsilon r^2} \mathbf{a}_r$$

The voltage  $V$  across the capacitor conductors is found by evaluating the line integral of the electric field along the contour  $C$  from the outer conductor to the inner conductor.

$$\begin{aligned} V &= -\int_C \mathbf{E} \cdot d\mathbf{l} = -\int_b^a \left( \frac{Q}{4\pi\epsilon r^2} \mathbf{a}_r \right) \cdot (-dr)(-\mathbf{a}_r) \\ &= -\frac{Q}{4\pi\epsilon} \int_b^a \frac{dr}{r^2} = -\frac{Q}{4\pi\epsilon} \left[ -\frac{1}{r} \right]_b^a \\ &= \frac{Q}{4\pi\epsilon} \left[ \frac{1}{a} - \frac{1}{b} \right] \end{aligned}$$

The ratio of charge to potential for the capacitor gives the capacitance:

$$C = \frac{Q}{V} = \frac{4\pi\epsilon}{\left[ \frac{1}{a} - \frac{1}{b} \right]} \quad \left( \begin{array}{c} \text{capacitance of an} \\ \text{ideal spherical capacitor} \end{array} \right)$$

## Resistance, Capacitance and Relaxation Time

If the medium between the conductors of a capacitor is not a perfect insulator, there is a finite resistance between the conductors (the resistance between the conductors is infinite when the medium is a perfect insulator). Assuming the medium between the capacitor conductors is a homogenous medium characterized by  $(\epsilon, \sigma)$ , the capacitance between the conductors is given by

$$C = \frac{Q}{V} = \frac{\iint \mathbf{D} \cdot d\mathbf{s}}{\int \mathbf{E} \cdot d\mathbf{l}} = \frac{\epsilon \iint \mathbf{E} \cdot d\mathbf{s}}{\int \mathbf{E} \cdot d\mathbf{l}}$$

while the resistance between the conductors is given by

$$R = \frac{V}{I} = \frac{\int \mathbf{E} \cdot d\mathbf{l}}{\iint \mathbf{J} \cdot d\mathbf{s}} = \frac{\iint \mathbf{E} \cdot d\mathbf{l}}{\sigma \int \mathbf{E} \cdot d\mathbf{s}}$$

If we take the product of the resistance and the capacitance, we find

$$RC = \frac{\epsilon \iint \mathbf{E} \cdot d\mathbf{s}}{\int \mathbf{E} \cdot d\mathbf{l}} \frac{\iint \mathbf{E} \cdot d\mathbf{l}}{\sigma \int \mathbf{E} \cdot d\mathbf{s}} = \frac{\epsilon}{\sigma} = T_r$$

where  $T_r$  is the relaxation time. Thus, given the capacitance for a particular capacitance geometry, the corresponding resistance can be determined easily according to

$$R = \frac{T_r}{C} = \frac{\epsilon}{C\sigma}$$

For the previously considered capacitors, we find the following resistance values:

Ideal parallel plate capacitor

$$C = \frac{\epsilon A}{d} \quad R = \frac{d}{\epsilon A} \frac{\epsilon}{\sigma} = \frac{d}{\sigma A}$$

Ideal coaxial capacitor

$$C = \frac{2\pi\epsilon L}{\ln(b/a)} \quad R = \frac{\ln(b/a)}{2\pi\epsilon L} \frac{\epsilon}{\sigma} = \frac{\ln(b/a)}{2\pi\sigma L}$$

Ideal spherical capacitor

$$C = \frac{4\pi\epsilon}{\left[\frac{1}{a} - \frac{1}{b}\right]} \quad R = \frac{\left[\frac{1}{a} - \frac{1}{b}\right]}{4\pi\epsilon} \frac{\epsilon}{\sigma} = \frac{\left[\frac{1}{a} - \frac{1}{b}\right]}{4\pi\sigma}$$

The equivalent circuit for these capacitors is shown below.

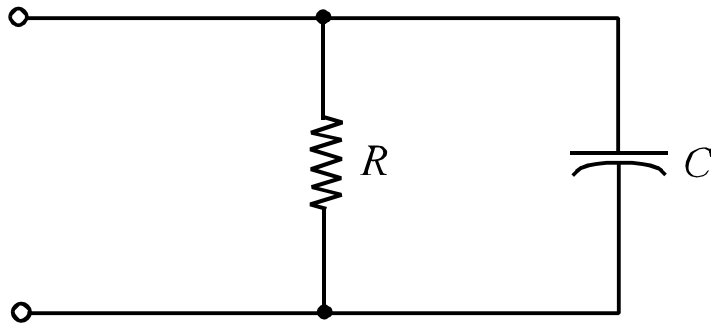

## Capacitors with Inhomogeneous Dielectrics

Each of the previously considered capacitor geometries has contained a homogeneous insulating medium between the capacitor conductors. For some geometries with inhomogeneous dielectrics, the capacitance can be shown to be a simple series or parallel combination of homogeneous dielectric capacitances.

We may use the analogies of total current in a resistor and total electric flux in a capacitor to identify series and parallel combinations of capacitors. The equations for the total current  $I$  in a resistor (in terms of current density  $J$ ) and the total electric flux  $\psi$  in a capacitor (in terms of electric flux density  $D$ ) follow the same form.

$$I = \iint_S \mathbf{J} \cdot d\mathbf{s} \qquad \psi = \iint_S \mathbf{D} \cdot d\mathbf{s}$$

Thus, the total current  $I$  in a resistor and the total electric flux  $\psi$  in a capacitor are analogous quantities and can be used to visualize the series and parallel combinations in capacitors with inhomogeneous dielectrics.

Series (common current/flux, distinct voltages)

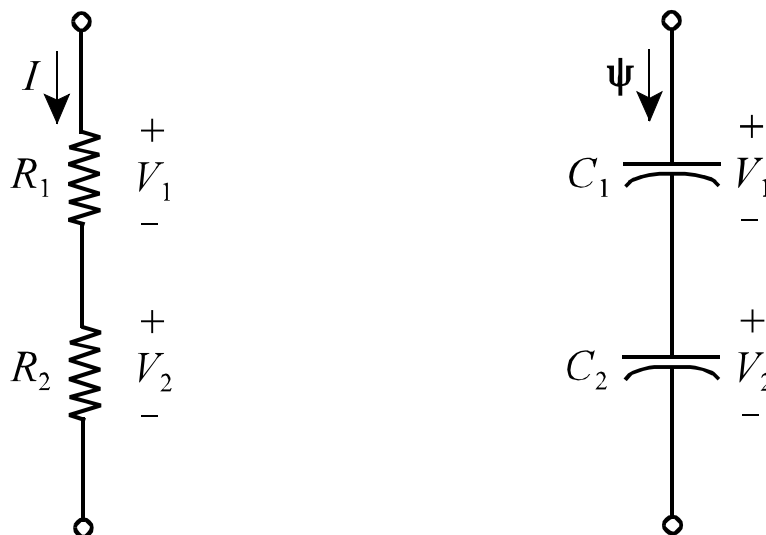

Parallel (common voltage, distinct currents/fluxes)

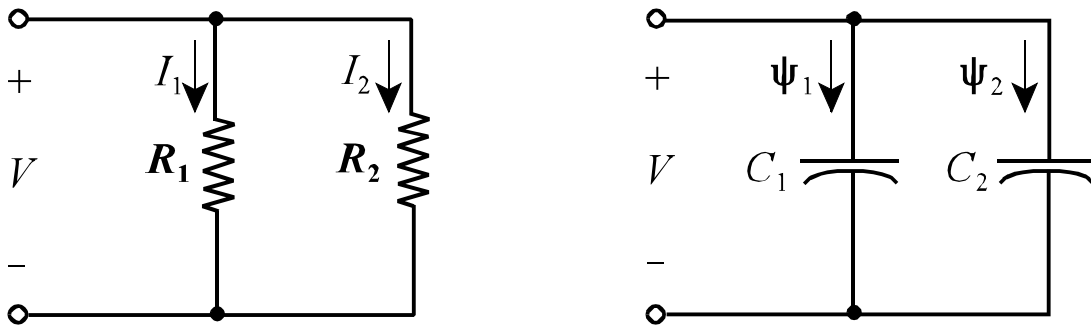

Example (Equivalent series capacitances)

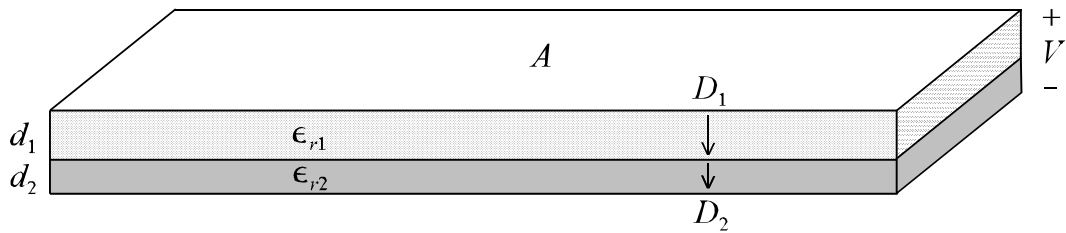

Boundary condition  $\Rightarrow D_1 = D_2$  (normal  $D$  is continuous)

The common electric flux through the two dielectric regions denotes a series capacitance combination. Even though no conductor exists on the interface between the dielectrics, this configuration can be viewed as two capacitors in series by placing two total charges of  $+Q$  and  $-Q$  (net charge = 0) on the interface.

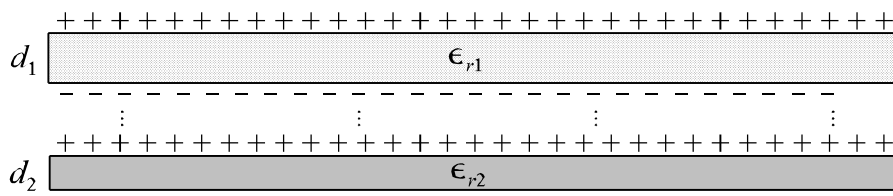

The overall capacitance of the inhomogeneous dielectric capacitor ( $C$ ) is found using the homogeneous dielectric capacitance equation applied to the two dielectric regions.

$$C_1 = \frac{\epsilon_o \epsilon_{r1} A}{d_1} \quad C_2 = \frac{\epsilon_o \epsilon_{r2} A}{d_2}$$

The series combination of these two capacitances is

$$C = \frac{C_1 C_2}{C_1 + C_2}$$

Example (Equivalent parallel capacitances)

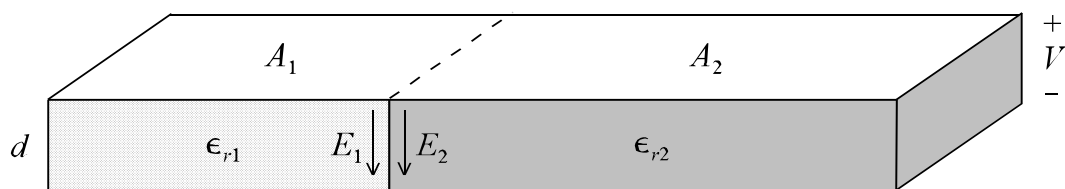

Boundary condition  $\Rightarrow E_1 = E_2$  (tangential  $E$  is continuous)

Since the electric field is equal in both regions, the electric flux density is distinct in the two regions (parallel capacitors). The capacitances of the individual regions are

$$C_1 = \frac{\epsilon_o \epsilon_{r1} A_1}{d} \quad C_2 = \frac{\epsilon_o \epsilon_{r2} A_2}{d}$$

The overall capacitance ( $C$ ) of the parallel combination is

$$C = C_1 + C_2$$

## Conductors in Electric Fields (Induced Charges)

When a conductor is placed in an applied electric field, charges are induced on the surface of the conductor that produce a secondary electric field (induced electric field). The total electric field is the superposition of the applied electric field and the induced electric field. For a perfect conductor ( $\sigma = \infty$ , PEC - perfect electric conductor), the induced electric field exactly cancels the applied field to yield a total field of zero inside the conductor. The applied electric field separates the charge on the conductor (positive charge forced in the direction of the applied field, negative charge forced in the direction opposite to that of the applied field).

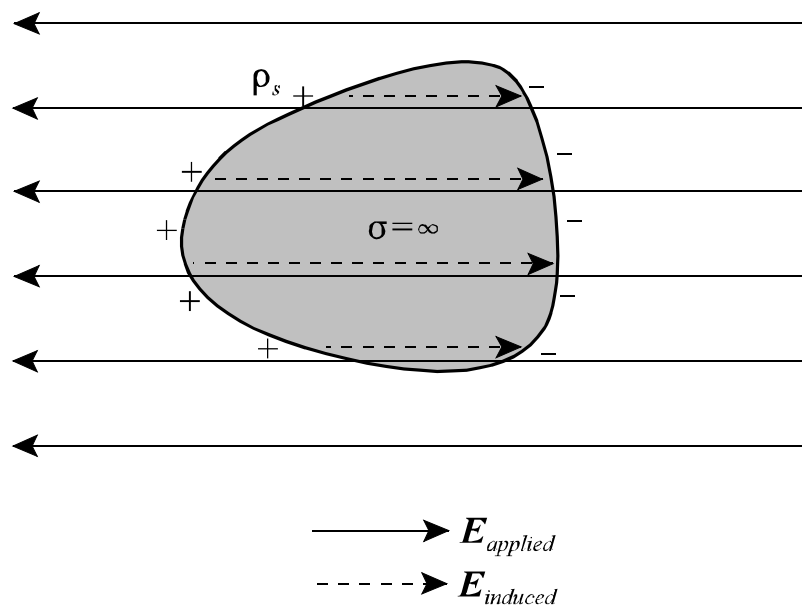

$$\mathbf{E}_{total} = \mathbf{E}_{applied} + \mathbf{E}_{induced} \quad (\text{everywhere})$$

$$\mathbf{E}_{total} = \mathbf{E}_{applied} + \mathbf{E}_{induced} = 0 \quad (\text{inside the PEC})$$

$$\mathbf{E}_{induced} = -\mathbf{E}_{applied} \quad (\text{inside the PEC})$$

Thus, the charge distribution induced on the surface of the PEC produces an induced electric field that exactly cancels the applied electric field inside the PEC. The total field outside the PEC is the sum of the applied electric field and the induced electric field due to the induced surface charge.

## Image Theory (Method of Images)

Given a charge distribution and/or a current distribution over a PEC ground plane, *image theory* may be used to determine the total fields above the ground plane without ever having to determine the surface charges and/or currents induced on the ground plane. Image theory is based on the electric field boundary condition on the surface of the perfect conductor (the tangential electric field is zero on the surface of a PEC). Using image theory, the ground plane boundary condition is satisfied by replacing the ground plane by equivalent image currents or charges located an equal distance below the ground plane.

Example (Image theory / point charge over ground)

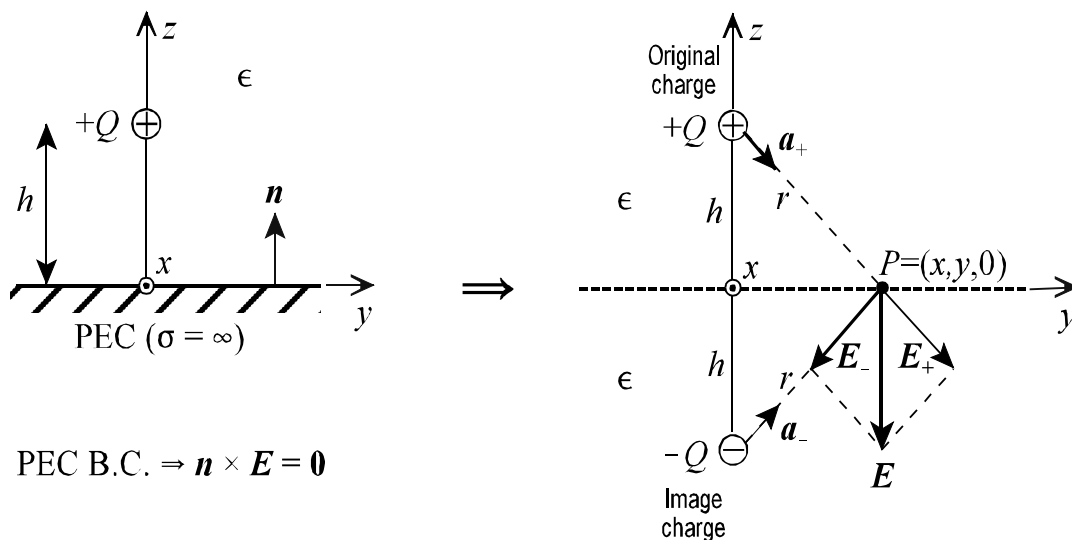

The total electric field at some arbitrary point  $P$  located on the ground plane is

$$\begin{aligned} \mathbf{E}(P) &= \mathbf{E}_+(P) + \mathbf{E}_-(P) \\ &= \frac{+Q}{4\pi\epsilon r^2} \mathbf{a}_+ + \frac{-Q}{4\pi\epsilon r^2} \mathbf{a}_- = \frac{Q}{4\pi\epsilon r^2} (\mathbf{a}_+ - \mathbf{a}_-) \end{aligned}$$

The vectors pointing from the point charges  $+Q$  and  $-Q$  to the field point  $P$  ( $\mathbf{r}_+$  and  $\mathbf{r}_-$ , respectively) are

$$\mathbf{r}_+ = (x\mathbf{a}_x + y\mathbf{a}_y) - (h\mathbf{a}_z)$$

$$\mathbf{r}_- = (x\mathbf{a}_x + y\mathbf{a}_y) - (-h\mathbf{a}_z)$$

The corresponding unit vectors  $\mathbf{a}_+$  and  $\mathbf{a}_-$  are

$$\mathbf{a}_+ = \frac{\mathbf{r}_+}{r} = \frac{x\mathbf{a}_x + y\mathbf{a}_y - h\mathbf{a}_z}{r}$$

$$\mathbf{a}_- = \frac{\mathbf{r}_-}{r} = \frac{x\mathbf{a}_x + y\mathbf{a}_y + h\mathbf{a}_z}{r}$$

where

$$r = \sqrt{x^2 + y^2 + h^2}$$

The total electric field on the ground plane due to the original point charge and its image charge is

$$\begin{aligned} \mathbf{E}(P) &= \frac{Q}{4\pi\epsilon r^2} (\mathbf{a}_+ - \mathbf{a}_-) \\ &= \frac{Q}{4\pi\epsilon r^2} \frac{-2h\mathbf{a}_z}{r} = -\frac{Qh}{2\pi\epsilon r^3} \mathbf{a}_z \end{aligned}$$

The corresponding electric flux density on the ground plane is

$$\mathbf{D}(P) = \epsilon \mathbf{E}(P) = -\frac{Qh}{2\pi r^3} \mathbf{a}_z$$

According to the boundary condition on the ground plane surface, the surface charge density on the ground plane is

$$\rho_s(P) = D_n(P) = -\frac{Qh}{2\pi r^3}$$

The procedure for handling a point charge over ground may be expanded to line, surface or volume charge distributions over ground using superposition. Each differential element of charge in the charge distribution may be “imaged” point by point.

