

Folded Dipole

A folded dipole is formed by connecting two parallel dipoles of radius a and length l at the ends to form a narrow loop. The center-to-center separation of the parallel wires is s . The separation distance s is always assumed to be small relative to wavelength.

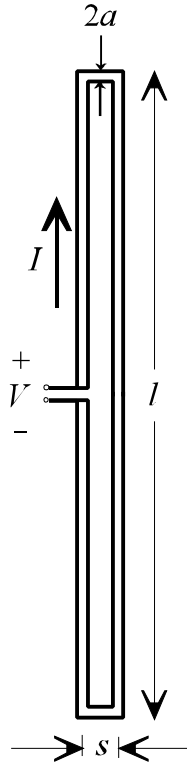

The input impedance of the folded dipole is defined (as is any other antenna) by the ratio of voltage to current at the antenna feed point.

$$Z_{\text{folded dipole}} = \frac{V}{I}$$

The folded dipole operates as an unbalanced transmission line. The current on the folded dipole can be decomposed into two distinct modes: an antenna mode (currents flowing in the same direction yielding significant radiation) and a transmission line mode (currents flowing in opposite directions yielding little radiation).

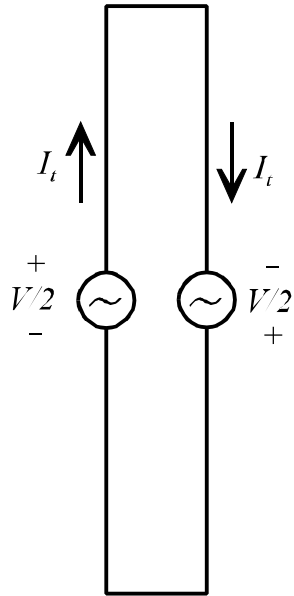

Transmission line mode

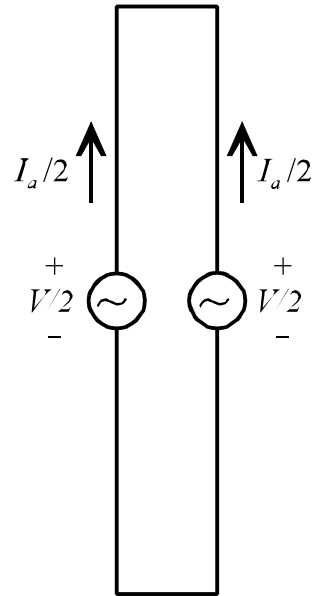

Antenna mode

Note that the superposition of the two modes yields the folded dipole input voltage V on the left wire and zero on the right wire. The transmission line current I_t in both antenna conductors must be the same in order to satisfy Kirchoff's current law at the ends of the antenna. The total antenna current I_a must be split equally between the two antenna conductors to yield the proper results for the radiated fields (the folded dipole radiates like two closely spaced dipoles). The total folded dipole input current can then be defined as the sum of the transmission line and antenna currents such that

$$I = I_t + \frac{I_a}{2}$$

so that the folded dipole input impedance may be written as

$$Z_{\text{folded dipole}} = \frac{V}{\left(I_t + \frac{I_a}{2} \right)}$$

The folded dipole impedance is determined by relating the transmission line and antenna mode currents to the corresponding input voltage.

We may insert an equivalent set of voltage sources into the transmission line mode problem in order to view the folded dipole as a set of two shorted transmission lines of length $l/2$. Note that both of the shorted transmission lines are driven with a source voltage of $V/2$ across its input terminals. The voltage and current for the transmission lines are related by

$$I_t = \frac{V/2}{Z_t} = \frac{V}{2Z_t}$$

where Z_t is the input impedance of a shorted two-wire line of length $l/2$ with wire of radii a with a center-to-center spacing of s . The general equation for the input impedance of a transmission line of characteristic impedance Z_o and length l terminated with an load impedance Z_L is

$$Z_{in} = Z_o \frac{Z_L + jZ_o \tan \beta l}{Z_o + jZ_L \tan \beta l}$$

For the shorted line, $Z_L = 0$ and the length is $l/2$ so that

$$Z_t = jZ_o \tan \left(\frac{\beta l}{2} \right)$$

The characteristic impedance of the two wire line transmission line is

$$Z_o = \frac{\eta}{\pi} \ln \left[\frac{s}{2a} + \sqrt{\left(\frac{s}{2a} \right)^2 - 1} \right]$$

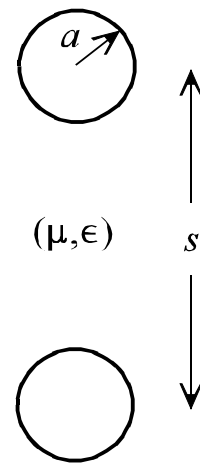
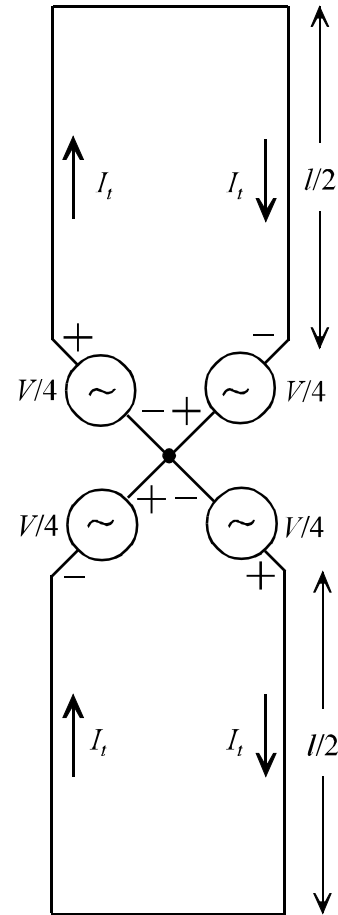

The folded dipole antenna current can be related to an equivalent dipole (treating the parallel currents as coincident for far field purposes) by

$$I_a = \frac{V/2}{Z_d} = \frac{V}{2Z_d}$$

where Z_d is the input impedance of a dipole of length l and equivalent radius a_e . The equivalent radius is necessary because of the close proximity of the two wires (capacitance) which alters the current distribution from that seen on an isolated dipole. The equivalent radius is given by

$$a_e = \sqrt{as}$$

The impedance Z_d is given by

$$Z_d = R_{in} + jX_{in}$$

$$R_{in} = \frac{R_r}{\sin^2\left(\frac{kl}{2}\right)} \quad X_{in} = \frac{X_A}{\sin^2\left(\frac{kl}{2}\right)}$$

$$R_r = \frac{\eta}{2\pi} \left\{ C + \ln(kl) - C_i(kl) + \frac{1}{2} \sin(kl) [S_i(2kl) - 2S_i(kl)] \right. \\ \left. + \frac{1}{2} \cos(kl) [C + \ln(kl/2) + C_i(2kl) - 2C_i(kl)] \right\}$$

$$X_A = \frac{\eta}{4\pi} \left\{ 2S_i(kl) + \cos(kl) [2S_i(kl) - S_i(2kl)] \right. \\ \left. - \sin(kl) \left[2C_i(kl) - C_i(2kl) - C_i\left(\frac{2ka_e^2}{l}\right) \right] \right\}$$

Given the relationships between the transmission line and antenna mode currents and voltages, the input impedance of the folded dipole can be written as

$$Z_{folded\ dipole} = \frac{V}{\left(I_t + \frac{I_a}{2}\right)} = \frac{V}{\frac{V}{2Z_t} + \frac{V}{4Z_d}}$$

$$= \frac{8Z_tZ_d}{4Z_d + 2Z_t}$$

$$Z_{folded\ dipole} = \frac{4Z_tZ_d}{Z_t + 2Z_d}$$

For the special case of a folded dipole of length $l = \lambda/2$, the input impedance of the equivalent transmission line is that of a shorted quarter-wavelength transmission line (open-circuit).

$$Z_t = jZ_o \tan\left(\frac{\beta l}{2}\right) = jZ_o \tan\left(\frac{2\pi}{\lambda} \frac{\lambda}{4}\right) = jZ_o \tan\left(\frac{\pi}{2}\right) = \infty$$

The impedance of the half-wave folded dipole becomes

$$Z_{folded\ dipole} = \lim_{Z_t \rightarrow \infty} \left[\frac{4Z_tZ_d}{Z_t + 2Z_d} \right] = 4Z_d \approx 300 \Omega$$

The half-wave folded dipole can be made resonant with an impedance of approximately 300Ω which matches a common transmission line impedance (twin-lead). Thus, the half-wave folded dipole can be connected directly to a twin-lead line without any matching network necessary. In general, the folded dipole has a larger bandwidth than a dipole of the same size.