

NAME: _____

You may NOT use a calculator.

problem 1.

$$\begin{array}{r} 0x3A \\ + 0xE8 \\ \hline 0x22 \end{array}$$

problem 2.

$$\begin{array}{r} 0x24 \\ - 0xE8 \\ \hline 0x3C \end{array}$$

1. (2 pts) Give the 8-bit result in hex.

rightmost digit: $0xA + 0x8 = 10 + 8 = 18$; $18 > 16$, so carry into next digit; result digit = $18 - 16 = 2$.
 leftmost digit: $0x3 + 0xE + 1$ (carry from previous digit)
 $= 3 + 14 + 1 = 18$; ($18 > 16$), so $18 - 16 = 2$ (leftmost digit result, carry out of most significant digit)

2. (2 pts) Give the 8-bit result in hex.

rightmost digit: $0x4 - 0x8 = 4 - 8$; ($4 < 8$), need borrow from next digit = $(16 + 4) - 8 = 20 - 8 = 12 = 0xC$, result digit
 leftmost digit: $0x2 - 0xE - 1$ (borrow from previous digit)
 $= 2 - 14 - 1 = 2 - 15$; ($2 < 15$), so need borrow from next digit = $(16 + 2) - 15 = 18 - 15 = 3$ (borrow out of most significant digit).

3. (2 pts) What is the value 0x80 in decimal?

$$0x80 = 8 * 16 + 0 * 16 = 128 + 0 = 128$$

4. (2 pts) The diagram to the right is from the PIC18F242 datasheet.

If A = '1', B = '0', C = '1', then give the logic values on the outputs of gate1, gate2, and the I/O pin.

VDD is power supply = '1'.
 VSS is ground = '0'.
 P is a P-type CMOS transistor.
 N is a N-type CMOS transistor.

gate1(OR) output is 1 (OR gate), gate2 (AND) output is 1, IO pin value is 0.

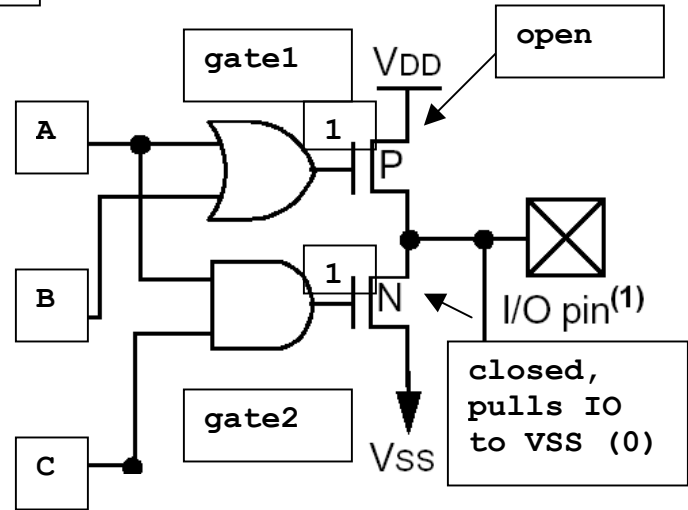

5. (2 pts) What values do T0CS (0 or 1), PSA (0 or 1) have to be for the TMR0L counter clock input to see the FOSC/4 input?

